

**Public Interest Energy Research (PIER) Program  
PROJECT REPORT**

**HUMBOLDT COUNTY AS A RENEWABLE  
ENERGY SECURE COMMUNITY**

**Analysis and Strategic Planning**

**Final Report - DRAFT**

Prepared for: California Energy Commission

Prepared by: Redwood Coast Energy Authority and  
Schatz Energy Research Center, Humboldt State University



MARCH 2013

PIR-08-034



**Prepared by:**

**Primary Author:**

Jim Zoellick - Senior Research Engineer, SERC

**Also Contributing:**

Andrea Alstone, Peter Alstone, Dr. Charles Chamberlin,  
Richard Engel, Ruben Garcia, Dr. Steven Hackett,  
Dr. Peter Lehman, Eric Martin, Luke Scheidler,  
Colin Sheppard - SERC  
Lori Biondini, Matthew Marshall - RCEA

Schatz Energy Research Center  
Humboldt State University  
Arcata, CA 95521  
707-826-4345  
www.schatzlab.org

**Contract Number: PIR-08-034**



**Prepared for:**

Public Interest Energy Research (PIER)  
**California Energy Commission**

Michael Sokol  
**Project Manager**

Kenneth Koyama  
**Office Manager**  
**Energy Generation Research Office**

Thom Kelly, Ph.D.  
**Deputy Director**  
**Energy Research & Development Division**

Melissa Jones  
**Executive Director**

**DISCLAIMER**

This report was prepared as the result of work sponsored by the California Energy Commission. It does not necessarily represent the views of the Energy Commission, its employees or the State of California. The Energy Commission, the State of California, its employees, contractors and subcontractors make no warrant, express or implied, and assume no legal liability for the information in this report; nor does any party represent that the uses of this information will not infringe upon privately owned rights. This report has not been approved or disapproved by the California Energy Commission nor has the California Energy Commission passed upon the accuracy or adequacy of the information in this report.

## **ACKNOWLEDGEMENTS**

We would like to thank the staff and interns of the Redwood Coast Energy Authority and the Schatz Energy Research Center at Humboldt State University who participated in this study. We would like to thank the members of our Professional Advisory Committee who so generously donated their time and expertise to help ensure the results of this study are relevant and realistic. We would like to thank the many other technical advisors who we called upon during this study for technical guidance and assistance, as well as the individuals and organizations that provided us with information and data to support our analyses. We would like to thank Pacific Gas and Electric Company for their generous support of this project and for providing technical advice and data. We would like to thank staff at the National Renewable Energy Laboratory for their assistance, in particular with the Jobs and Economic Development Impact (JEDI) models. We would like to thank Terry Uyeki of the California Center for Rural Policy for her assistance with the stakeholder engagement process. We would like to thank all of the RePower Humboldt stakeholders who contributed to the process. Finally, we would like to thank the staff at the California Energy Commission for their generous support of this project.

### **Redwood Coast Energy Authority**

Jacoba Aldersebaes  
Dana Boudreau  
David Boyd  
Forest Sariano

### **Pacific Gas and Electric Company**

Ian Caliendo  
Marco Rios  
Alison Talbott  
Joscelyn Wong

### **Schatz Energy Research Center**

Tom Quetchenbach  
Adam Schumaker

### **Professional Advisory Committee**

Obadiah Bartholomy, Sacramento Municipal Utility District  
Don Dame, Northern California Power Agency  
Easan Drury, National Renewable Energy Laboratory  
Kirk Girard, County of Humboldt  
Garvin Heath, National Renewable Energy Laboratory  
Brian Jungers, E Source  
Jeff Leonard, Eureka City Council  
Tim Lipman, UC Berkeley  
Bob Marino, DG Fairhaven Power, LLC  
David Rubin, Pacific Gas and Electric Company  
Sascha von Meier, California Institute for Energy and Environment



## PREFACE

The California Energy Commission Public Interest Energy Research (PIER) Program supports public interest energy research and development that will help improve the quality of life in California by bringing environmentally safe, affordable, and reliable energy services and products to the marketplace.

The PIER Program conducts public interest research, development, and demonstration (RD&D) projects to benefit California.

The PIER Program strives to conduct the most promising public interest energy research by partnering with RD&D entities, including individuals, businesses, utilities, and public or private research institutions.

PIER funding efforts are focused on the following RD&D program areas:

- Buildings End-Use Energy Efficiency
- Energy Innovations Small Grants
- Energy-Related Environmental Research
- Energy Systems Integration
- Environmentally Preferred Advanced Generation
- Industrial/Agricultural/Water End-Use Energy Efficiency
- Renewable Energy Technologies
- Transportation

*Humboldt County as a Renewable Energy Secure Community: Analysis and Strategic Planning* is the final report for the Humboldt County Renewable Energy Secure Community: Planning for Renewable-based Energy Security and Prosperity in Humboldt County project (contract number PIR-08-034) conducted by the Redwood Coast Energy Authority. The information from this project contributes to PIER's Renewable Energy Technologies Program.

For more information about the PIER Program, please visit the Energy Commission's website at [www.energy.ca.gov/research/](http://www.energy.ca.gov/research/) or contact the Energy Commission at 916-654-4878.

## ABSTRACT

The goal of the Humboldt County Renewable Energy Secure Community project was to develop a strategic plan for Humboldt County to develop its local renewable energy resources in an effort to meet 75 percent to 100 percent of its local electricity demand as well as a significant fraction of its heating and transportation energy needs. An additional objective was to reduce energy related greenhouse gas emissions in a cost-effective manner. The project team conducted technical and economic analyses to assess local energy demand, identify available resources, and determine the ability to meet renewable energy project goals. The team explored financing and ownership options, assessed the regulatory and political framework, and developed a strategic plan in consultation with local stakeholders via a public process.

Key findings from the study are that Humboldt County can meet most of its electricity needs and a substantial portion of its heating and transportation energy needs using local renewable resources. The project team estimates that this can be achieved at a cost increase of 5 percent to 15 percent while reducing greenhouse gas emissions by 35 percent to 45 percent and creating hundreds of local jobs. Energy efficiency, as well as biomass, wind, and small hydroelectric energy resources can play key roles. However, numerous challenges will need to be overcome. For example, widespread fuel switching from fossil fuels to renewable electricity in the transportation and heating sectors will be necessary to cost-effectively achieve large greenhouse gas reductions. Substantial upgrades to the local electrical transmission and distribution system will be necessary, but not cost prohibitive.

To build required public support, the authors recommend that the public be involved in a meaningful way in project planning and development and that community concerns regarding local project impacts be addressed. The report presents a set of long-term strategies and near-term next steps. The authors recommend implementation of the strategic plan, which, if done successfully, will bring local and statewide benefits.

**Keywords:** California, renewable, energy, secure, community, economic, impact, jobs, strategic, planning, local, government, electricity, grid, integration, ownership, financing, levelized cost, modeling, optimization, supply, demand, efficiency, transportation, heating, greenhouse gas, research, analysis, Humboldt County, fuel switching, stakeholder, outreach, public process

Please use the following citation for this report:

Zoellick, Jim. (Schatz Energy Research Center, Humboldt State University). 2013. *Humboldt County as a Renewable Energy Secure Community: Analysis and Strategic Planning*. California Energy Commission. Publication number: CEC-XXX-2010-XXX.

# TABLE OF CONTENTS

<b>Acknowledgements</b> .....	<b>i</b>
<b>PREFACE</b> .....	<b>iii</b>
<b>ABSTRACT</b> .....	<b>iv</b>
<b>TABLE OF CONTENTS</b> .....	<b>v</b>
<b>LIST OF FIGURES</b> .....	<b>viii</b>
<b>LIST OF Tables</b> .....	<b>ix</b>
<b>EXECUTIVE SUMMARY</b> .....	<b>1</b>
<b>CHAPTER 1: Introduction</b> .....	<b>9</b>
1.1 Problem Statement.....	9
1.2 Goals and Objectives .....	10
1.3 Project Metrics .....	11
1.4 Project Team .....	11
1.5 Background.....	12
1.5.1 Energy Use .....	12
1.5.2 Energy Supply .....	13
1.5.3 Renewable Energy Resources .....	14
1.5.4 Energy Transmission Infrastructure .....	14
<b>CHAPTER 2: Project Approach</b> .....	<b>17</b>
2.1 Professional Advisory Committee .....	18
2.2 Resource and Technology Assessment.....	19
2.2.1 Energy Resource Options .....	20
2.2.2 Energy Technology Options.....	25
2.2.3 Energy Balance Model Methodology.....	29
2.2.4 Key Data Sources .....	31
2.2.5 Interconnection Feasibility Study .....	32
2.2.6 Hydrogen Fueled Transit Assessment.....	34
2.2.7 Forest-based Biofuels Assessment.....	35

2.3	Development, Financing, and Ownership Options .....	35
2.4	Economic Analysis.....	36
2.4.1	Cost Analysis.....	36
2.4.2	Economic Impact Assessment.....	37
2.5	Regulatory and Political Issues.....	37
2.6	Stakeholder Analysis.....	37
2.6.1	Stakeholder Groups.....	38
2.6.2	Stakeholder Meetings.....	38
2.6.3	Additional Stakeholder Activities.....	40
2.7	Strategic Plan.....	40
2.8	Community Outreach .....	42
2.9	RESCO Planning Workbook .....	42
<b>CHAPTER 3: Project Outcomes.....</b>		<b>43</b>
3.1	Resource and Technology Assessment.....	43
3.1.1	Energy Modeling Results.....	43
3.1.2	Interconnection Feasibility Study Results.....	50
3.1.3	Hydrogen Transit Results.....	52
3.1.4	Forest-based Biofuels Results.....	53
3.1.5	Key Findings.....	54
3.2	Development, Financing and Ownership Options.....	55
3.2.1	Development and Ownership Models .....	55
3.2.2	Financing Options.....	58
3.3	Economic Analysis.....	59
3.3.1	Renewable Energy Cost Results .....	59
3.3.2	Economic Impact Results.....	62
3.4	Regulatory and Political Issues.....	67
3.4.1	Regulatory and Policy Guide.....	67
3.4.1	Regulatory and Political Issues Memo .....	67

3.5	Stakeholder Analysis.....	70
3.6	Strategic Plan .....	71
3.6.1	Long-term Strategies and Near-term Implementation Measures.....	73
3.7	Community Outreach .....	77
3.7.1	Outreach Activities .....	77
3.7.2	Outreach Materials .....	77
3.7.3	Outreach Plan.....	80
3.8	RESCO Planning Workbook .....	81
<b>CHAPTER 4: Conclusions and Recommendations .....</b>		<b>83</b>
4.1	Conclusions.....	83
4.2	Lessons Learned.....	83
4.3	Recommendations .....	85
4.4	Suggestions for Further Research.....	85
4.5	Benefits to California .....	86
<b>CHAPTER 5: References .....</b>		<b>87</b>
<b>CHAPTER 6: Glossary.....</b>		<b>92</b>

## LIST OF FIGURES

Figure 1.1: Humboldt County Electricity Load Duration Curve .....	13
Figure 1.2: Humboldt County 2010 Electricity Supply by Source (920 GWh) .....	14
Figure 1.3: Humboldt County Natural Gas Pipeline .....	15
Figure 1.4: Humboldt Area Electricity Transmission Schematic .....	16
Figure 1.5: Humboldt Area Electricity Transmission Map .....	16
Figure 2.1: Existing and Potential Sites for Electricity Production in Humboldt County .....	21
Figure 2.2: Regional Energy Planning Optimization Model.....	30
Figure 2.3: Locations of New Generation Facilities and Interconnection Points .....	34
Figure 2.4: RePower Humboldt Strategic Planning Process .....	41
Figure 3.1: Example Hourly Supply and Demand Profile from REPOP Model .....	44
Figure 3.2: Optimality Curve (Curve C) - Minimize Emissions with Various Cost Ceilings .....	45
Figure 3.3: Portfolios from Optimality Curve C .....	46
Figure 3.4: Optimality Curves With Varying Limits on the Penetration of Electric Vehicles and Heat Pumps.....	48
Figure 3.5: Installed Capacities for BAU, Bold, and Peak Scenarios .....	49
Figure 3.6: Percent Electricity from each Generator for BAU, Bold, and Peak Scenarios.....	49
Figure 3.7: Comparison of Costs and Benefits for BAU, Bold, and Peak Scenarios .....	50
Figure 3.8: Instant Capital Cost Estimates .....	60
Figure 3.9: Humboldt County Marginal Cost of Supply .....	61
Figure 3.10: Levelized Cost of Energy Estimates.....	62
Figure 3.11: Construction Phase Job Creation per MW(a) .....	63
Figure 3.12: Operations Phase Job Creation per MW(a).....	64
Figure 3.13: Operations and Construction Phase Job Creation for BAU and Bold Scenarios.....	66
Figure 3.14: Total Annual Job Creation for BAU, Bold and Peak Scenarios.....	66
Figure 3.15: RePower Humboldt Strategic Plan Cover and Table of Contents.....	72
Figure 3.16: RePower Humboldt Strategic Plan Key Findings.....	72
Figure 3.17: RePower Humboldt Strategic Plan Summary Table of Near-Term Implementation Measures.....	74

## LIST OF TABLES

Table 2.1: Decision Variables Used in the Optimizations and Their Corresponding Boundary Constraints .....	31
Table 2.2: Energy Resource Data Sources .....	32
Table 2.3: Electricity and Natural Gas Demand Data Sources .....	32
Table 2.4: New Generation Sources Considered in Interconnection Feasibility Study .....	33
Table 2.5: Description of Fuel Pathways Modeled in GREET .....	35
Table 2.6: Stakeholder Participation in RePower Humboldt Meetings.....	39
Table 2.7: Criteria for Evaluating Renewable Energy Projects .....	39
Table 3.1: Transmission System Upgrade Alternatives Developed by PG&E to Mitigate Development of 253 MW of Renewable Generation.....	51
Table 3.2: Well-to-Wheels Total Energy, Fossil Fuels, and GHG Emissions for Biomass Fuel Pathways .....	53
Table 3.3: RePower Humboldt Outreach Activities .....	79



# EXECUTIVE SUMMARY

## Introduction

In 2009 the California Energy Commission awarded the Redwood Coast Energy Authority a Renewable-based Energy Secure Community (RESCO) grant to evaluate and plan for RESCO opportunities for Humboldt County, California. A RESCO is a community that obtains the majority of its energy supply (electricity and fuel) from local renewable energy resources, thereby making itself more energy secure.

Humboldt County shows great potential to become a renewable energy secure community. The county is geographically isolated, making RESCO status even more important. It has a relatively small electrical demand (170 MW peak), and a wealth of local renewable energy resources, including wind, wave, biomass and small hydro. In addition, Humboldt County boasts a large number of energy savvy early adopters (for example, rooftop solar and hybrid vehicle owners) and has strong community resources in the form of the Redwood Coast Energy Authority (a local Joint Powers energy office) and the Schatz Energy Research Center at Humboldt State University. Humboldt County has demonstrated the interest, expertise, and resource potential to become a renewable energy secure community; what was needed was a detailed assessment and a corresponding strategic plan for the orderly, capital efficient development of local renewable energy resources in a manner that could best capture the environmental, economic, and social benefits for the County.

## Project Goal

The initial goal of the Humboldt County RESCO project was to develop a strategic plan for Humboldt County to develop its local renewable energy resources in an effort to meet 75 percent to 100 percent of the local electricity demand, as well as a significant fraction of heating and transportation energy needs. As the project developed, however, it became clear that a plan with a solitary goal of increasing the amount of locally generated renewable electricity was not optimal. Instead, the project team modified the planning goal to minimize greenhouse gas emissions by increasing the use of local renewable resources and deploying key enabling technologies, such as plug-in electric vehicles. This resulted in a plan that can achieve a more cost effective reduction in greenhouse gas emissions, while also developing substantial amounts of local renewable energy resources. The team assessed a full range of renewable resources and enabling technologies and proposed a long-term development strategy and near-term steps.

## Project Approach

The project team included the Redwood Coast Energy Authority, the Schatz Energy Research Center at Humboldt State University, and Pacific Gas and Electric Company (PG&E). In addition, a project advisory committee composed of experts in the energy field provided review and feedback on project activities and outcomes. Key project tasks are listed below.

- Assess resource and technology options
- Examine development, financing and ownership options

- Conduct economic analysis
- Examine regulatory and political issues
- Conduct stakeholder analysis
- Develop strategic plan
- Create community outreach plan
- Develop planning workbook

The project team's approach was to first conduct the technical and economic analyses to identify available energy resources and technologies, assess their ability to meet renewable energy goals within system constraints, and assess their economic efficiency. In addition, the team assessed financing and ownership options that could be used to develop local renewable energy projects. The team also assessed the regulatory and political framework that renewable energy projects will be subjected to. These research products constituted a set of technical background reports that supported the strategic planning process.

Once this information was compiled, the project team began engaging local stakeholders to solicit their input in crafting a strategic plan that identified a preferred path forward. The team then shared the plan with the larger community, solicited public input, and modified the plan to reflect public input. Finally, a RESCO planning workbook was developed to document the Humboldt RESCO planning process, making the process accessible to other communities that may want to pursue RESCO development. At key stages in the project, the authors shared methods and outcomes with a Professional Advisory Committee.

#### *Resource and Technology Assessment*

The purpose of the resource and technology assessment was to determine which local renewable energy resources and associated energy technologies could be used to meet Humboldt County's renewable energy goals. To accomplish this, the project team developed a regional energy balance model and used it to simulate various scenarios. The model estimated energy demand and supply across the electricity, heating and transportation sectors. The modeling team tracked energy costs and greenhouse gas emissions and used these outputs to compare the impacts of various scenarios. They also employed an optimization algorithm to identify the best mix of resources and technologies. In addition, PG&E conducted an interconnection feasibility study to evaluate the transmission impacts of a representative scenario of future renewable energy development in Humboldt County.

#### *Economic Analysis*

The team assessed the costs and economic impacts associated with a clean energy development plan for Humboldt County. The analysis examined the construction, operations, and maintenance costs associated with each renewable energy category as compared to the costs of natural gas-fired generation at the Humboldt Bay Generating Station. Additionally, the team estimated costs associated with more aggressive energy efficiency programs and a transition from conventional heating and transportation technologies to heat pumps and electric vehicles.

In addition to the cost analysis, the team conducted an economic impact assessment, forecasting the jobs and economic activity that could be directly or indirectly attributed to new renewable energy development.

## Project Findings and Outcomes

Results from the resource and technology assessment and economic analysis tasks were fundamental to the development of the Humboldt RESCO Strategic Plan. Below is a set of key findings from these tasks.

- Humboldt County can meet 75 percent or more of its electricity needs and a large fraction of its heating and transportation energy demand using local renewable energy resources. This can result in a substantial reduction in greenhouse gas emissions (35 percent to 45 percent below business-as-usual) and can be achieved at a modest cost increase (5 percent to 15 percent above business-as-usual). The key issues facing Humboldt County are not related to the adequacy of local resources, but instead to the ability to develop these resources and the associated energy infrastructure needed to serve local demand with local renewable energy sources.
- There are many possible resource and technology options to choose from, and a mixed portfolio of options is likely more advantageous than any technology in isolation. Aggressive implementation of cost-effective energy efficiency opportunities should be a near-term pursuit. Biomass, wind, and small run-of-the-river hydroelectric energy sources should play key supply-side roles.
- The RESCO goal of meeting 75 percent or more of electric demand with local renewable resources may not be the best metric for measuring success. Instead, the project team recommends the focus be on cost-effective options to decrease *overall* greenhouse gas emissions across the whole energy sector.
- Fuel switching to plug-in hybrid and battery-only electric vehicles in the transportation sector and to electric heat pumps in the heating sector has the potential to play a major role in helping Humboldt County to realize its RESCO vision. Fuel switching opportunities are critical to cost-effectively achieving large reductions in energy related greenhouse gas emissions. Without fuel switching, deep reductions in greenhouse gas emissions are infeasible.
- In addition to energy security and climate change mitigation benefits, the RESCO vision offers Humboldt County significant economic development benefits. It is estimated that 100 to 300 permanent additional full-time jobs could be created through implementation of the RESCO vision.
- An interconnection feasibility study conducted by PG&E indicates that substantial upgrades to the local transmission and distribution system will be required to accommodate large-scale development of local renewable energy sources. The most cost-effective plan for these upgrades would likely involve an area-wide planning approach that simultaneously considers multiple projects. If instead a project-by-project approach is taken, a less optimal piecemeal solution is likely to result. It is also

important to note that non-standard approaches to maintaining grid stability, such as curtailing generation, should be considered in the analysis. Finally, transmission planning should also consider the possibility of creating a community-scale microgrid in Humboldt that can operate independently of the statewide grid if necessary, thereby providing added energy security to the Humboldt area.

- Energy storage is not expected to play a significant role in the near- or even intermediate-term. This is due to the tremendous load following capabilities of the PG&E Humboldt Bay Generating Station and the 70 MW of available transmission capacity connecting the county to the statewide electric grid.
- If there is no further development of clean energy alternatives in Humboldt County, electric supply will likely be dominated by power from the natural gas-fired PG&E Humboldt Bay Generating Station and existing biomass power plants. The heating and transportation sectors will continue to be dominated by fossil fuels in the form of natural gas for heating and gasoline for transport. Transportation fuels will continue to dominate annual energy costs, and transportation fuels and natural gas usage will drive greenhouse gas emissions to 25 percent greater than 1990 levels. Clearly the business-as-usual scenario will not improve local energy sustainability, but instead will exacerbate the environmental problems associated with the current energy system while maintaining Humboldt County's exposure to geographic isolation, fuel scarcity, and price volatility problems.

In addition to these technical lessons, there were many lessons learned in the regulatory and political realm. An assessment of project development, financing, and ownership options revealed numerous opportunities and identified key strategies for Humboldt County. In addition, the examination of regulatory and political issues and the community stakeholder analysis provided valuable insights. Key challenges and lessons learned are summarized below.

- On-shore wind power is likely to face siting challenges and could benefit from proactive planning, permitting and outreach efforts.
- Biomass energy faces uncertainties and potential barriers, including fuel costs, sustainability, and public perception and climate neutrality issues.
- Small, run-of-the-river hydroelectric development faces significant regulatory, permitting, and transmission access issues.
- Low natural gas prices and Renewable Portfolio Standard quotas being reached have depressed prices for renewable electricity. While these may be short-lived transient conditions, they currently pose challenges to project developers and owners/operators of both existing and new renewable energy projects.
- A distrust of large corporations can make securing outside capital more challenging and creates a preference for locally owned, community-based projects.
- There is a lack of consumer choice allowing for purchase of renewable energy, especially from local projects.

- There is a strong preference for local participation and control in energy planning and development.
- People want to see real, tangible benefits for their communities associated with proposed projects, especially if they perceive they are giving something up in the process.
- The community can benefit from an education and outreach campaign that provides information about how much energy is consumed, where it comes from, what the alternatives are, and what the associated impacts are.
- Because of community concerns regarding local impacts of renewable energy projects, there is a need for transparent processes that involve the community in planning and project development activities in a meaningful way.
- Planning, permitting, and regulatory hurdles for renewable energy projects point to a need for proactive efforts that can help streamline the project development process, identify preferred sites, develop programmatic environmental reviews, and develop land use zones that are compatible with renewable energy development.

#### *Key Project Deliverables*

- The project team developed a RESCO strategic plan, called *RePower Humboldt*, and shared it with the community. The community provided substantial input and is engaged in an ongoing dialog about moving the plan forward.
- The project team produced and published two technical reports to provide detailed documentation of the resource and technology assessment and the economic analysis tasks.
- The team developed a *Regulatory and Policy Guide on Renewable Energy and Energy Efficiency for Humboldt County Local and Tribal Governments*. This will provide local leaders with action-oriented strategies for promoting sustainable energy development in their communities.
- The team developed a RePower Humboldt Community Outreach Plan to be implemented by the Redwood Coast Energy Authority.
- The team produced a RESCO Planning Workbook to document the planning process and make it accessible to other communities.

#### **Conclusions and Recommendations**

The project team met key goals and objectives. They authored a strategic action plan for Humboldt County that can lead to development of local renewable energy resources which can meet the majority of local electricity demand, as well as a significant fraction of heating and transportation energy needs. The plan was well received by the local community, and the community is now engaged in an important dialog regarding the path forward. Humboldt County has a great opportunity to become a renewable energy secure community. The energy

resources and necessary technologies exist. Now the county is equipped with a well-conceived plan, and community and project team members have begun to develop significant expertise and knowhow to ensure the plan moves forward.

### *Recommendations*

The authors make the following recommendations as key next steps to move the *RePower Humboldt Strategic Plan* forward.

- Implement the education and outreach plan and secure endorsements from key constituencies; form working groups to move the plan forward.
- Work to expand the Redwood Coast Energy Authority's local energy efficiency efforts.
- Conduct proactive planning and regulatory efforts that can streamline the development process, identify preferred sites, develop programmatic environmental review, and establish renewable energy zones.
- Promote plug-in electric vehicle adoption and deploy charging infrastructure.
- Promote and develop distributed generation projects.
- Develop an "all-in-one" program that offers a full array of energy services in the areas of energy efficiency and distributed generation to both commercial and residential customers. The program should support participants from start to finish in their sustainable energy projects. Services could include: project evaluation; financing; project management; interconnection, permitting, and incentive paperwork; bulk purchasing; standardized pricing; and pre-approved contractors).

### *Suggestions for Further Research*

- Conduct research, development, and demonstration of biomass energy conversion technologies that can decrease transportation costs, increase system efficiencies, and provide added value (for example, biomass gasification to fuel cell generator and torrefaction technologies).
- Conduct a biomass energy assessment study to determine the available biomass supply and associated fuel cost for local biomass resources. Assess greenhouse gas and forest management implications of local biomass use; work to build a consensus on acceptable biomass energy policy in the county.
- Conduct a heat pump pilot study to assess the performance and cost-effectiveness of air-source heat pumps in the North Coast region. Examine opportunities to streamline permitting and overcome market barriers.
- Pursue opportunities to attract wave energy, offshore wind energy, and osmotic power research, development, and demonstration projects to Humboldt County. Pursue development of a research, development, demonstration, and deployment facility at the former Samoa Pulp Mill site.

### *Benefits to California*

- The Humboldt County RESCO Strategic Plan will support Humboldt County and other communities throughout the state to develop local renewable energy resources and implement sustainable energy policies. These efforts will help the State of California meet many of its energy and climate protection goals, including: Renewable Portfolio Standard, Alternative Fuels Plan, Zero Emission Vehicle Action Plan, Bioenergy Action Plan, Clean Energy Jobs Plan, Distributed Generation and Cogeneration Policy, and AB 32 Global Warming Solutions Act of 2006.
- Local community energy planning is a new policy and planning area. The policy and planning tools developed through the Humboldt County RESCO project will provide significant value to many other California communities. The strategic planning process has been documented in the RESCO Planning Workbook to make this information easily accessible to other communities and to facilitate replication.
- Many lessons (for example, the importance of electric vehicles) have been learned through the energy planning and analysis work, assessment of regulatory and political issues, and stakeholder analysis process. Many, if not all of these lessons are transferrable to other communities. These lessons learned have been made easily accessible to other communities via the RESCO Planning Workbook.
- The RESCO Strategic Plan identifies cost-effective approaches to improving energy sustainability and mitigating climate change and demonstrates that there are energy, environment, and economic benefits to be gained. These positive impacts can benefit ratepayers throughout the state.



# CHAPTER 1:

## Introduction

In 2008 the California Energy Commission's Public Interest Energy Research (PIER) Renewables Program released a grant solicitation called Renewable-based Energy Secure Communities (RESCOs), PON-08-004. RESCOs were defined as communities that obtain their energy supply (electricity and fuel) through primary reliance (up to 100 percent) on indigenous renewable energy resources, and thereby make themselves more energy secure. The purpose of the grant program was to support research, development, and demonstration of community-scale, integrated renewable energy projects. A requirement of the program was that proposed projects must integrate multiple geographically convenient renewable energy resources along with enabling energy technologies, and must address technical, economic, and environmental barriers to RESCO implementation.

RESCO projects offer many benefits. They rely on smaller, distributed energy plants exploiting high quality local resources, and thereby might avoid some of the problems that face larger utility scale projects (constrained transmission access, environmental impacts, permitting hurdles, and public opposition). Community scale projects can also realize efficiency gains due to lower transmission system losses, the potential for combined heat and power applications, and the ability to integrate numerous technologies, including efficiency, demand response, energy storage, and other enabling technologies. Finally, RESCOs offer many benefits to local communities, including economic development opportunities, climate change mitigation strategies, and energy security benefits.

In 2009 the Energy Commission awarded the Redwood Coast Energy Authority a RESCO grant to conduct an exploratory study into the RESCO opportunities for Humboldt County, California.

### 1.1 Problem Statement

If California is to meet its aggressive greenhouse gas (GHG) reduction and renewable energy goals, select communities will need to become early adopters and set an example for other communities to follow. Humboldt County shows great potential to become a near-term renewable energy secure community (RESCO).

Humboldt County has an electrical system that is geographically isolated from the larger state grid. It has a small electrical demand, a wealth of local renewable energy resources, and a local natural gas-fired power plant that is ideally suited to following changes in the intermittent supply of renewable electricity.

There are already strong commitments from the Humboldt County community to work to develop local renewable resources. The County has developed an Energy Element as part of its General Plan Update, a joint powers authority (the Redwood Coast Energy Authority) has been formed to develop and implement sustainable energy initiatives, and two local cities and the

County have joined the Cities for Climate Protection program and are pursuing GHG reduction activities. What the community lacked was a detailed assessment of its renewable energy resources and a corresponding strategic plan for their orderly, capital efficient development.

## **1.2 Goals and Objectives**

The initial goal of the Humboldt County RESCO project was to develop a strategic action plan for Humboldt County to develop its local renewable energy resources in an effort to meet 75 percent to 100 percent of the local electricity demand, as well as a significant fraction of heating and transportation energy needs. As the project developed, however, it became clear that a plan with a solitary goal of increasing the amount of locally generated renewable electricity was not optimal. Instead, the project team modified the planning goal to cost-effectively minimize greenhouse gas emissions by increasing the use of local renewable resources and deploying key enabling technologies, such as plug-in electric vehicles. The plan would assess a full range of renewable resources and identify an integrated mix that can be coupled with energy efficiency and demand management to best meet the county's needs and best capture associated environmental, economic, and social benefits. The plan would specify a long-term development strategy and identify near-term steps the County should take.

Project objectives included:

- Identify and assess various integrated mixes of renewable energy resources and technologies that will allow Humboldt County to meet most or all of its electricity needs and a large fraction of its heating and transportation energy needs using locally available renewable energy resources.
- Identify and assess renewable energy resources and technology options that are currently ready for commercial development, as well as those that offer promise for long-term development.
- Identify integrated renewable energy resource and technology options that will function acceptably on Humboldt County's local electricity grid.
- Identify possible development structures and financing and ownership options that could accelerate the development of local renewable energy resource and technology options.
- Conduct an economic analysis of various resource and technology options and identify the most favorable solutions that optimize environmental, economic and societal benefits for the community.
- Identify potential regulatory and political hurdles that will need to be overcome to allow for comprehensive renewable resource development and propose possible solutions.
- Identify and engage key stakeholders and develop a plan to successfully cultivate community support.
- Compile project information into a succinct, action oriented strategic plan that reports the study's findings and lays out a clear path to move the community forward in developing its renewable energy resources.

- Document the Humboldt RESCO strategic planning process in a workbook that can be used by other communities seeking RESCO status.

### **1.3 Project Metrics**

Successful outcomes for this project were identified as follows:

- The strategic plan should garner strong community and stakeholder support and be likely to be implemented.
- Participants should develop memorandums of understanding, collaborative agreements, or partnerships among various stakeholders with the stated purpose of moving the RESCO vision forward.
- Local government should support the RESCO vision and integrate it into the local government planning and policy framework.
- Local leaders should identify near-term pilot projects and potential funding sources and foster partnerships to move these projects forward.

Long-term success will be measured by the percentage of renewable energy that eventually serves Humboldt County's electricity, heating and transportation energy needs.

### **1.4 Project Team**

The project team included the Redwood Coast Energy Authority (a Joint Powers Authority), the Schatz Energy Research Center at Humboldt State University (a university research group), and PG&E (the local investor-owned utility).

The Redwood Coast Energy Authority (RCEA) was the prime contractor. RCEA was formed in 2003 with the purpose to develop and implement sustainable energy initiatives that reduce energy demand, increase energy efficiency, and advance the use of clean, efficient, and renewable resources available in the region. RCEA is a Joint Powers Authority (JPA), representing seven local municipalities (the Cities of Arcata, Blue Lake, Eureka, Ferndale, Fortuna, Trinidad and Rio Dell), the County of Humboldt, and the Humboldt Bay Municipal Water District. As a JPA, RCEA is governed by a board composed of representatives from each of its member jurisdictions and is authorized to plan and help implement a RESCO vision for Humboldt County. As the regional energy authority, the County Board of Supervisors has designated RCEA to implement Energy Element strategies on a regional basis through a Comprehensive Action Plan for Energy. The RCEA Board adopted a resolution (Resolution number RCEA 2009-1) to pursue and carry out this proposed RESCO project.

The Schatz Energy Research Center (SERC) at Humboldt State University supported RCEA in this project. SERC was founded in 1989 with a mission to promote the use of clean and renewable energy resources. Over the years SERC has been involved in extensive research, planning, design, and analysis activities for the development and implementation of sustainable

energy systems, including energy efficiency, solar, wind, small hydro, biomass, and hydrogen and fuel cell technology for portable, stationary, and transportation applications. SERC and RCEA have worked together since RCEA's inception. SERC has conducted local energy analysis, training, and public outreach services on behalf of RCEA. In 2005, SERC worked closely with RCEA to develop an Energy Element for Humboldt County's General Plan Update. Through this effort SERC gained substantial knowledge of local energy use characteristics and the availability of local renewable energy resources and opportunities for their development.

Partnering on this RESCO project with RCEA and SERC was the local investor-owned utility, Pacific Gas and Electric Company (PG&E). PG&E has ambitious goals to reduce its GHG emissions and to increase the portion of renewable resources it provides to its customers in an environmentally sustainable and economically efficient fashion. As part of this project, PG&E provided technical data, technical assistance, and collaborative partnership.

## **1.5 Background**

Humboldt County is geographically isolated. It has a small electrical demand (170 MW peak), and a wealth of local renewable energy resources, including wind, wave, and biomass. It has been estimated (Schatz Energy Research Center, 2005) that Humboldt County's renewable energy resources could meet all of the county's energy needs for electricity, transportation, and heating. Local biomass fired generators already supply 25 percent to 30 percent of the local electricity demand, and small, primarily run-of-the-river hydro provides another 5 percent. Recently two new renewable energy projects were proposed, but not implemented: a 50 MW wind farm and a 5 MW pilot scale wave energy project. Also, PG&E has recently re-powered the Humboldt Bay Generating Station (HBGS), a local natural gas-fired power plant. The new plant consists of ten 16 MW high efficiency engine generators that are ideally suited to following changes in demand and in the intermittent supply of renewable electricity.

Humboldt County's connections to larger energy grids are tenuous. The county has only one connection to the larger natural gas grid and two major connections (115 kV) to the larger electric grid. At approximately 60-70 MW, the normally available capacity of the electrical transmission lines that connect Humboldt County to the larger grid is less than half of the county's peak electrical demand. For this reason Humboldt County generates much of its own electricity. However, despite the County's tremendous potential supply of indigenous renewable energy sources, it currently imports the majority of its energy in the form of natural gas and petroleum products.

### **1.5.1 Energy Use**

In Humboldt County energy is used as a transportation fuel and as electricity and heat in homes, businesses, industries, and agriculture. In 2010 it is estimated that Humboldt County's end-use energy consumption totaled about 16 petajoules (PJ). Over half (57 percent) of the energy was used as a transportation fuel (gasoline and diesel), while the remainder was split rather evenly between electrical demands and natural gas heating demands. Because of inefficiencies in the generation and transmission of electricity, the county's primary energy

consumption totaled about 22 PJ. Primary energy sources consisted mainly of natural gas, gasoline, diesel, and biomass.

Humboldt County's electricity use in 2010 totaled about 920 GWh (California Energy Commission, 2013), split nearly evenly between the residential and non-residential sectors. The Humboldt area is winter peaking, with a peak demand of about 170 MW. Average demand is 110 MW, and base load usage accounts for about 70 MW (PG&E, 2010). Figure 1.1 shows a typical load duration curve for Humboldt County.

**Figure 1.1: Humboldt County Electricity Load Duration Curve**

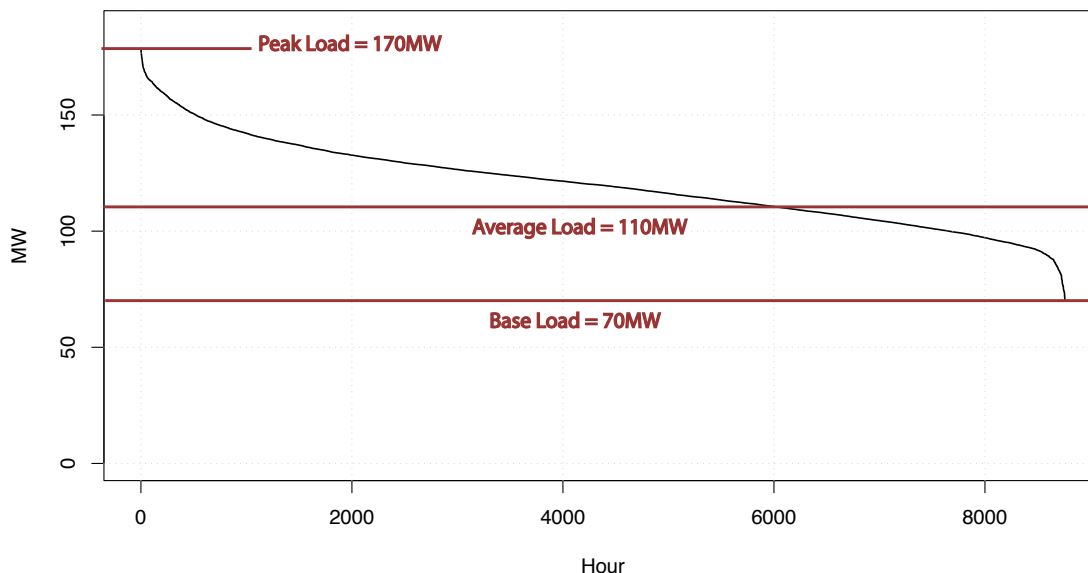

Source: Prepared by Schatz Energy Research Center, data from PG&E.

In Humboldt County, natural gas consumption in 2010 totaled an estimated 71 million therms, with a little more than half of this amount burned to produce electricity in PG&E's HBGS (California Energy Commission, 2010b). More than 60 percent of the remaining natural gas was consumed by the residential sector for heating and cooking. The rest was consumed by the commercial, industrial, agricultural, and mining sectors.

Gasoline and diesel consumption in Humboldt County in 2010 was estimated to be about 55 million gallons and 12 million gallons, respectively (California Energy Commission, 2011a). The use of transportation fuels is closely linked to the number of vehicle miles traveled. The county averages about 7 percent more vehicle miles traveled per capita than the state as a whole, though this pales in comparison to a couple of neighboring counties (Mendocino and Trinity), which exceed the state vehicle miles traveled per capita figure by over 50% (California Department of Transportation, 2009).

### 1.5.2 Energy Supply

In 2010 nearly three quarters of the primary energy used in Humboldt County was imported, with the remainder coming mainly from local biomass energy resources. Essentially all of the county's transportation fuels are imported. Although the majority of electricity is generated in the county, a large portion of it is generated using natural gas. The county imports about 90

percent of its natural gas; the rest is obtained locally from fields in the Eel River valley. The county has the capability of generating all of its own electricity. In fact, in 2001 during the California electricity crisis, Humboldt County was a net exporter of electricity. Figure 1.2 shows an estimate of the breakdown of electricity sources serving Humboldt County in 2010. Three wood-fired power plants, Fairhaven, Scotia, and Blue Lake, provided about 25 percent of the electrical energy needs. About 5 percent of electricity was supplied by small-scale hydropower (various plants no larger than 5 MW). PG&E’s HBGS provided about half of the needed electricity, and the remainder, approximately 19 percent, was imported.

**Figure 1.2: Humboldt County 2010 Electricity Supply by Source (920 GWh)**

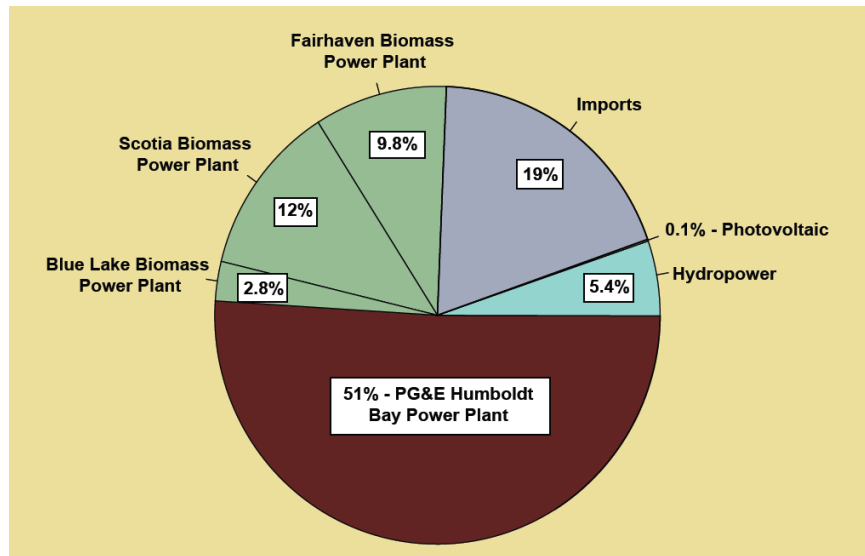

Source: Prepared by Schatz Energy Research Center; estimate based on Energy Commission data.

### 1.5.3 Renewable Energy Resources

Schatz Energy Research Center estimates that the total electricity generation from local renewable resources could provide as much as 1500 MW of generating capacity and over 6000 GWh per year of electrical energy (Schatz Energy Research Center, 2005). This includes power primarily from waves, wind, and biomass, with smaller contributions from small hydroelectric and solar. This is over six times the county’s current electricity consumption rate. However, there is a lot of uncertainty about how much of these resources can realistically be developed. For example, over 75 percent of the estimated renewable electricity resource would come from wave power, a technology that is in its early stages of development and therefore is quite uncertain. Even for well proven resources like biomass, wind, solar, and hydropower, there are many potential barriers that could impede development, including high costs, regulatory hurdles, lack of financing, siting and transmission access issues, and lack of public support. Nonetheless, the potential of these local resources is large and offers significant economic development potential.

### 1.5.4 Energy Transmission Infrastructure

Humboldt County is remotely located at the end of PG&E’s electricity and natural gas supply grids. There is one major natural gas supply line that comes from a compressor station in

Gerber in the Central Valley and follows a route roughly parallel to Highway 36 (Figure 1.3). This pipe is 12 inches in diameter and according to PG&E is capable of transporting enough natural gas to meet current local needs. There are no gas storage fields in the local area, though there are some native gas fields in the Eel River Valley. It is estimated that approximately 65 percent to 70 percent of the households in Humboldt County have access to the natural gas grid (Schatz Energy Research Center, 2005).

The Humboldt area electrical grid covers about 3000 square miles and is connected to the bulk PG&E transmission system by four transmission circuits, each ranging from 31 to 115 miles in length (Figures 1.4 and 1.5). Electricity imports mainly are through two 115 kV circuits that come from the east at Cottonwood and follow routes roughly parallel to Highway 36 and Highway 299. The lesser capacity circuits include a 60 kV circuit coming from the south at Bridgeville-Garberville (roughly parallel to Highway 101) and a second 60 kV line coming from Trinity in the east that ties into the 115 kV lines. The total electrical transmission capacity into Humboldt County through the existing lines is approximately 70 MW, less than half of the county’s current peak demand. Therefore, local generators are critical to meeting local electricity needs.

Humboldt County’s connection to PG&E’s larger electrical transmission grid serves many important functions. It supports wholesale market transactions and helps stabilize electricity prices, improves system stability and reliability, and provides additional voltage support. This connection allows electrical power to be imported, as well as exported.

**Figure 1.3: Humboldt County Natural Gas Pipeline**

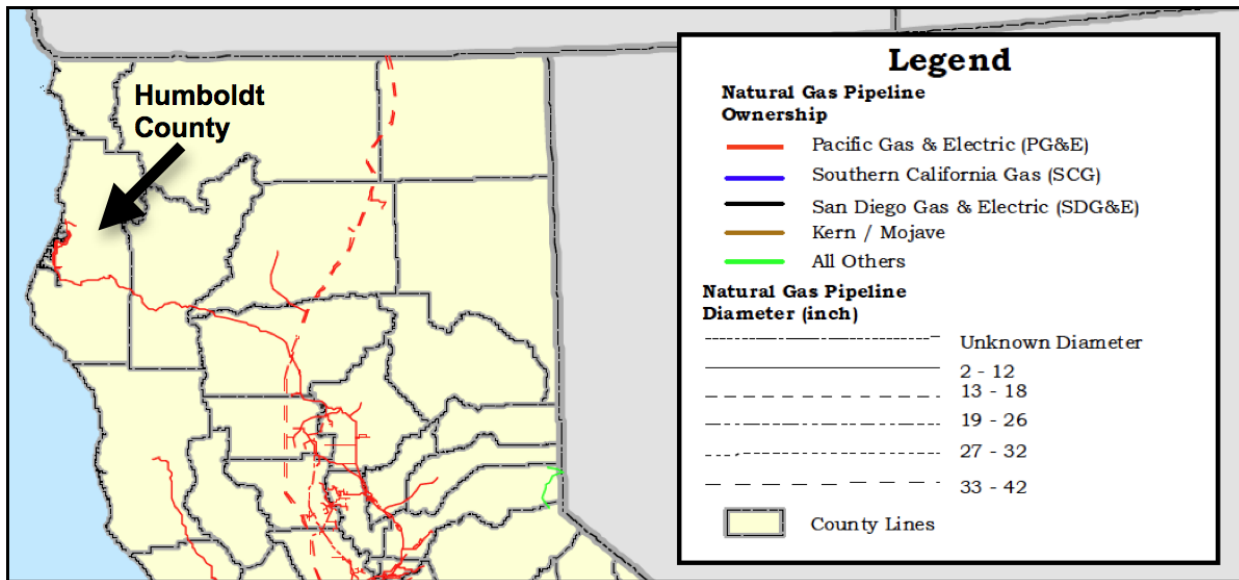

Source: Adapted from California Natural Gas Pipelines, California Energy Commission, Systems Assessment and Facilities Siting Division, Cartography Unit, [http://www.energy.ca.gov/maps/natural\\_gas.html](http://www.energy.ca.gov/maps/natural_gas.html).

**Figure 1.4: Humboldt Area Electricity Transmission Schematic**

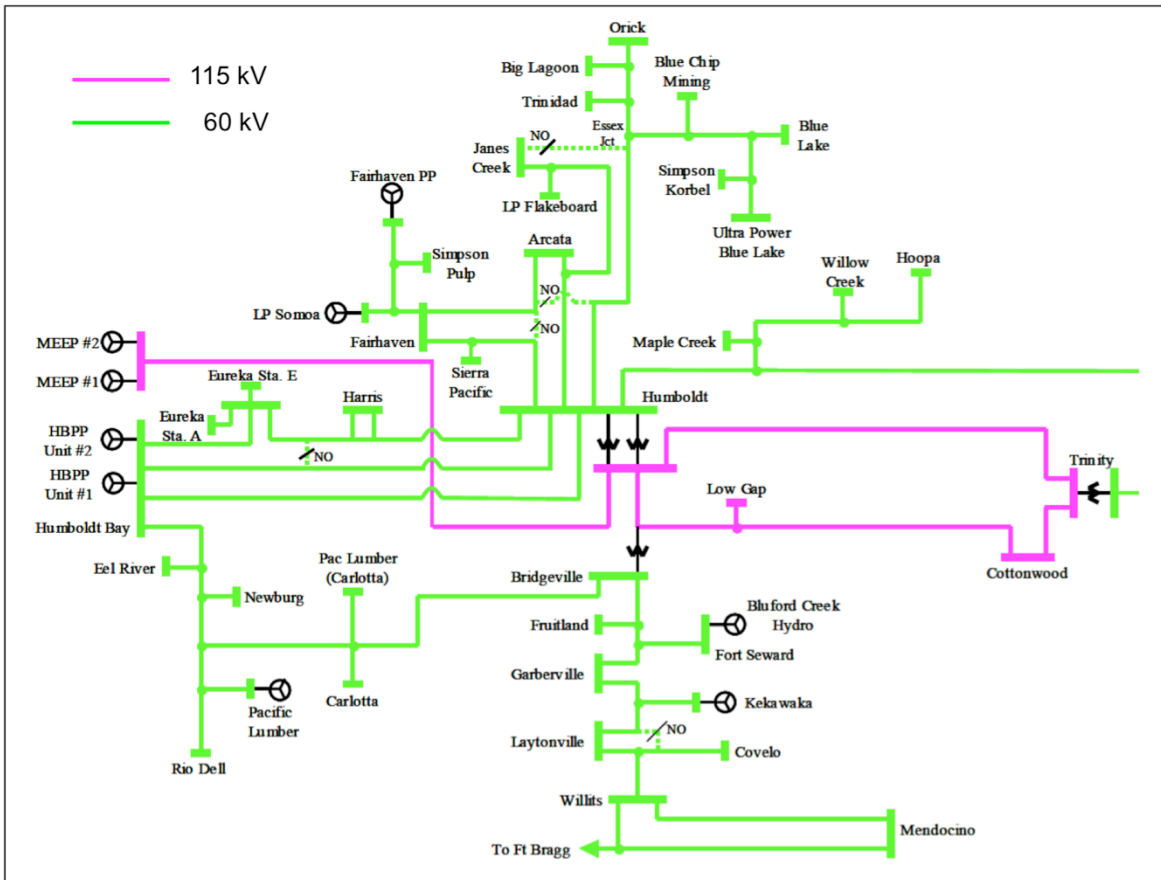

Source: Humboldt Long Term Transmission Assessment, Draft Study Report, Dave Casuncad, Electric T&D Engineering, Pacific Gas and Electric Company, January 13, 2005.

**Figure 1.5: Humboldt Area Electricity Transmission Map**

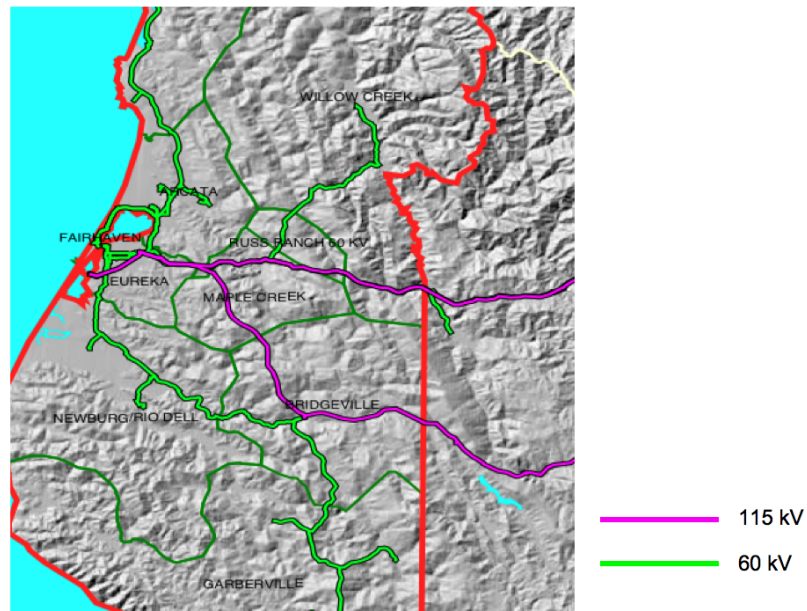

Source: Pacific Gas and Electric Company, undated.

## CHAPTER 2: Project Approach

The goal of the Humboldt County RESCO project was to develop a strategic action plan for Humboldt County to develop its local renewable energy resources in an effort to meet 75 percent to 100 percent of the local electricity demand as well as a significant fraction of heating and transportation energy needs. Below is a list of project tasks.

- Assess resource and technology options
- Examine development, financing and ownership options
- Conduct economic analysis
- Examine regulatory and political issues
- Conduct stakeholder analysis
- Develop strategic plan
- Create community outreach plan
- Develop planning workbook

The project team's approach was to first conduct the technical and economic analyses to identify available energy resources and technologies, assess their ability to meet renewable energy goals within system constraints, and assess their economic efficiency. In addition, the team assessed financing and ownership options that could be used to develop local renewable energy projects. The team also assessed the regulatory and political framework that renewable energy projects will be subjected to. These research efforts resulted in a set of technical background documents that supported the strategic planning process.

Once the project team had compiled this information, they began engaging local stakeholders to solicit their input in crafting a strategic plan. The team then shared the plan with the larger community, solicited public input, and modified the plan to reflect this public input. Finally, the team developed a planning workbook to document the RESCO planning process and make it accessible to other communities that may want to pursue RESCO development. At key stages in the project, the authors shared methods and outcomes with a Professional Advisory Committee (PAC), and the PAC posed clarifying questions and provided recommendations.

Midway through the Humboldt County RESCO project, the team made a decision to rebrand the project to make it more easily understood and better perceived by the local community. A new name, RePower Humboldt, was chosen and used from then on. For the purposes of this report the terms Humboldt RESCO project and RePower Humboldt project are used interchangeably.

This reports summarizes the methodology and outcomes associated with all of the project tasks. Below is a list of additional documents generated as deliverables for the project. These documents contain further details on the various tasks and outcomes associated with the

Humboldt RESCO Project. These documents can be accessed on the Redwood Coast Energy Authority website at <http://www.redwoodenergy.org/programs/repower>.

- *Humboldt County Renewable Energy Secure Community: Resource and Technology Assessment Report*. Zoellick, Jim, Colin Sheppard and Peter Alstone. (Schatz Energy Research Center, Humboldt State University). 2012.
- *Humboldt County as a Renewable Energy Secure Community: Database of Local Renewable Energy Sources and Current/Projected Energy Demands*. Sheppard, Colin. (Schatz Energy Research Center, Humboldt State University). 2011.
- Humboldt RESCO Task 3 Memo: Renewable Energy Development, Ownership and Financing Options
- *Humboldt County as a Renewable Energy Secure Community: Economic Analysis Report*. Hackett, Dr. Steven C., Luke Scheidler, and Ruben Garcia Jr. (Schatz Energy Research Center). 2012.
- RePower Humboldt Task 5 Memo: Regulatory and Political Issues – Challenges to Implementing the RePower Humboldt Strategic Plan
- *Regulatory and Policy Guide on Renewable Energy and Energy Efficiency for Humboldt County Local and Tribal Governments*, Schatz Energy Research Center, February 2013.
- Humboldt RESCO Task 6 Memo: Stakeholder Analysis
- *RePower Humboldt: A Strategic Plan for Renewable Energy Security and Prosperity*, Schatz Energy Research Center, February 2013.
- RePower Humboldt Community Outreach Plan
- Humboldt RESCO Planning Workbook

## 2.1 Professional Advisory Committee

The purpose of the Humboldt RESCO professional advisory committee (PAC) was to:

- Provide technical and professional guidance on the research and planning work being done.
- Provide input that would make the results of the study more realistic, more valuable, and more likely to be implemented.
- Provide input that would improve the relevance of the study on a state and national level.

The project team recruited PAC members in December of 2009 and convened three PAC meetings, one in March of 2010, one in February of 2011, and one in September of 2012. All meetings were held at the Schatz Energy Research Center at Humboldt State University in Arcata, California. PAC members either attended in person or participated via teleconference

and/or web conference. Primary feedback from PAC members focused on the resource and technology assessment, the economic analysis, and the strategic plan development.

PAC members included representatives from the list of organizations below.

- California Institute for Energy and the Environment, UC Berkeley
- City of Eureka and Redwood Coast Energy Authority Board
- DG Fairhaven Power, LLC (a local biomass power plant)
- E Source (private energy consultant)
- Humboldt County Community Development Services Department
- Northern California Power Agency (not-for-profit agency that provides support to community-owned utilities)
- National Renewable Energy Laboratory (NREL)
- Pacific Gas and Electric Company (PG&E)
- Sacramento Municipal Utility District (SMUD)
- Transportation Sustainability Research Center and Pacific Clean Energy Application Center at UC Berkeley

## **2.2 Resource and Technology Assessment**

The project team conducted a resource and technology assessment to determine which local renewable energy resources and associated energy technologies could be used to meet Humboldt County's renewable energy goals. Accordingly, the team developed a set of energy resource, energy storage, and demand management scenarios in an effort to provide at least 75 percent of local electricity demand and a significant portion of heating and transportation energy needs using local renewables. The team assessed these scenarios for their technical feasibility according to their ability to meet projected energy demands in the year 2030. In addition, the authors assessed the scenarios based on their expected cost, GHG emission impacts, and economic impacts. For one potential scenario, PG&E staff conducted an interconnection feasibility study to assess associated impacts to the local electric grid and required infrastructure upgrades.

The team developed a regional energy balance model that could be used to simulate various scenarios. The authors developed the Regional Energy Planning Optimization (REPOP) Model and used it to estimate energy demand and supply across the electricity, heating and transportation sectors. However, the model focused on the electricity sector. The authors modeled the region as a single node and dispatched power to meet demand on an hourly interval subject to various constraints. The model tracked energy costs and GHG emissions and used these outputs to compare the impacts of various scenarios. An optimization algorithm identified the best mix of resources and technologies. Model inputs included energy demand, energy resource, and energy technology data. The team also performed separate assessments of hydrogen fueled transit buses and forest-based biofuels.

Section 2.2.1 identifies and characterizes renewable energy resources in Humboldt County and specifies estimates of maximum available and modeled electrical capacities. Section 2.2.2 identifies and characterizes energy technology options. Section 2.2.3 presents the Regional Energy Planning Optimization Model. Section 2.2.4 outlines key data sources used in the analyses. Section 2.2.5 introduces the interconnection feasibility study conducted in partnership with PG&E. Sections 2.2.6 and 2.2.7 briefly describe the hydrogen fueled transit bus and forest-based biofuel assessments. A more detailed description of these analyses can be found in *Humboldt County Renewable Energy Secure Community: Resource and Technology Assessment Report* (Zoellick et al. 2012).

## 2.2.1 Energy Resource Options

Humboldt County is blessed with an abundant supply of energy resources, most of them renewable. Topping the list are wind, wave, and biomass. In addition, run-of-the-river hydro and solar energy resources are also available in substantial quantities. To a lesser extent there are various biogas resources that can be accessed. Finally, Humboldt County possesses a significant supply of natural gas in Eel River Valley. Each of these resources is discussed briefly below. Figure 2.1 highlights existing as well as a handful of potential future sites for electricity production.

### 2.2.1.1 Wind

The best wind resource in Humboldt County is in the Cape Mendocino area, where much of the onshore resource is rated at class 5 or better. It has been estimated that there is greater than 400 MW of onshore resource in this area (California Department of Water Resources, 1985). Shell WindEnergy recently studied Bear River Ridge, the most accessible ridge in the area. Shell had proposed a 50 MW wind farm on the ridge, but chose not to pursue the project due to “unfavorable market conditions and issues pertaining to the transportation logistics.” Public acceptance of the project was also an issue. Wind power in Humboldt County may face siting challenges; for example, the Audubon Society predominantly designates the Cape Mendocino area as an Important Bird Area. The RePower Humboldt study considered up to 250 MW of wind energy development.

### 2.2.1.2 Wave

Wave energy is an immature technology. Nonetheless, there is tremendous wave energy potential worldwide and tremendous interest in the technology. A study of the Humboldt County coastline (California Energy Commission, 2003) estimated the wave energy potential to be about 5000 MW. A conservative estimate is that as much as 1000 MW of this potential capacity could be developed (Schatz Energy Research Center, 2005). PG&E recently considered development of a 5 MW wave energy pilot project directly west of Humboldt Bay (PG&E, 2011b). While this project was suspended due to higher than expected development costs, permitting challenges, and technology immaturity, PG&E stated that they believe “that wave power will merit further evaluation, demonstration and deployment.” The maximum wave power capacity examined in this study was 100 MW.

**Figure 2.1: Existing and Potential Sites for Electricity Production in Humboldt County**

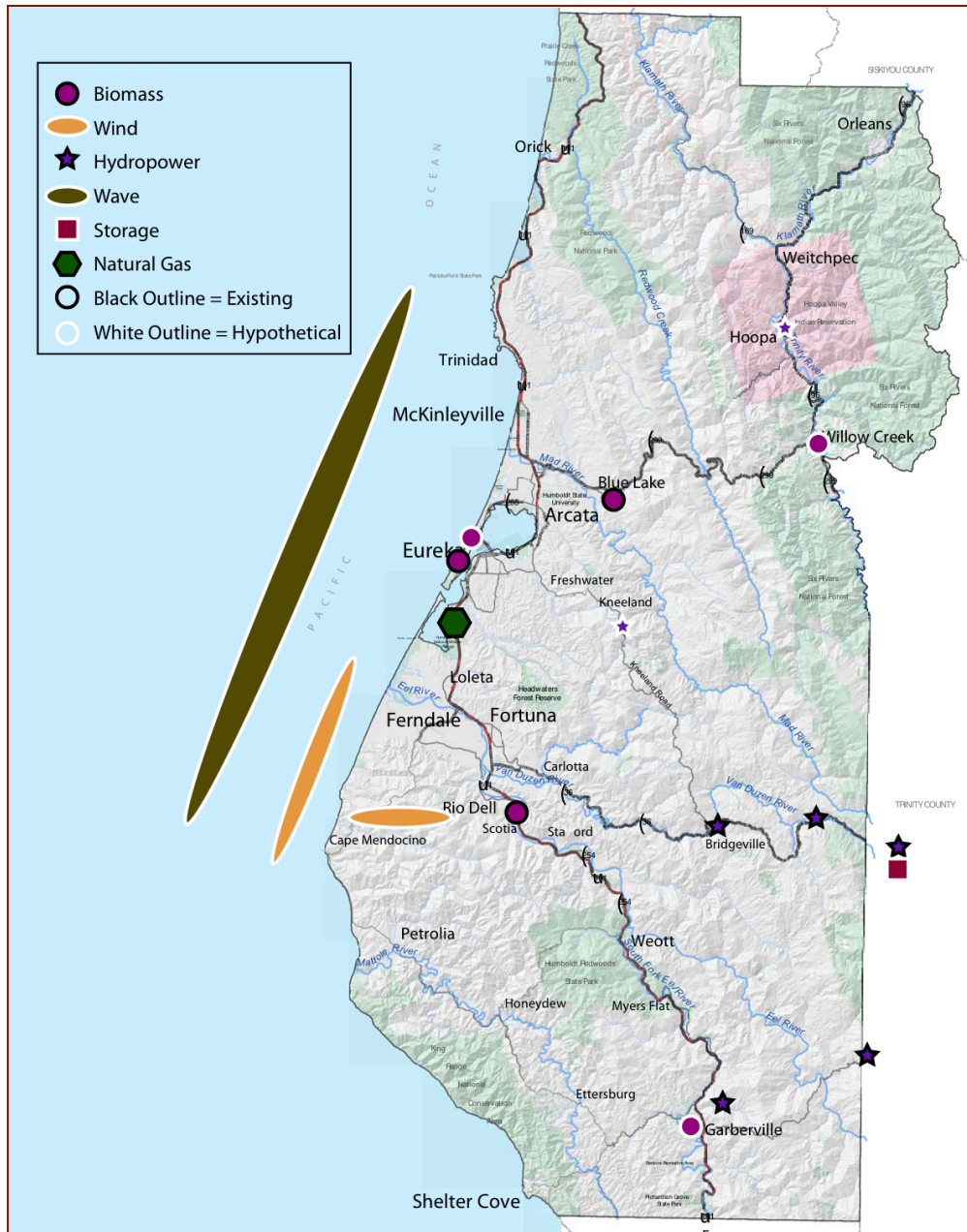

Source: Schatz Energy Research Center.

### 2.2.1.3 Forest Biomass

The primary biomass resource in Humboldt County is forest-based biomass. Humboldt County is blessed with a tremendous forest resource base, with 1.9 million acres (65 percent private) of forested land covering more than 80 percent of the county’s land area (Humboldt County, 2005). The timber harvest volume in Humboldt County in 2010 was 218,651 million board feet. This accounted for 19 percent of the timber harvest volume in the state, ranking Humboldt County as the number one timber production county in the State (CA State Board of

Equalization, 2010). However, timber harvest volumes in the county have decreased by almost 5 percent per year for more than a decade; this compares with a statewide decline of slightly above 4 percent per year.

For almost three decades Humboldt County has obtained a large portion of its electricity from conventional steam power plants with wood-fired grate stoker boilers. Since the 1980's there have been three plants: the 28 MW Greenleaf Power, LLC (Town of Scotia) power plant (formerly Pacific Lumber), the 18 MW DG Fairhaven Power, LLC plant (owned by EWP Renewable Company), and the 11 MW Blue Lake Power, LLC (formerly Ultrapower) plant owned by Renewable Energy Providers, Inc. The Fairhaven plant has run consistently for decades and sells all of its electricity to PG&E under long-term contract. The Blue Lake plant was offline for more than a decade, but recently has repowered and is selling power to San Diego Gas and Electric Company. The Scotia plant has recently changed ownership and is currently off-line, though it is expected to come on-line again later in 2013. This plant has traditionally sold some or all of its power to PG&E. Together, these plants typically meet 25 percent to 30 percent of Humboldt County's electricity needs.

Biomass fuel currently comes predominantly from wood waste from mill operations and forest slash left over from timber harvests. Another potential source is residue from thinning and forest fuel reduction programs aimed at minimizing forest fire hazards and improving forest health. While the existing plants currently use most available sawmill waste, there may be room for expansion of biomass power production if plants can economically use woody biomass from forest fuel reduction efforts.

The estimate of the available biomass resource used in this study comes from the findings of the California Biomass Collaborative (Williams, 2008), which was reported without modification from estimates developed by the California Department of Forestry and Fire Protection. The Biomass Collaborative estimates the forest biomass available for fuel use in Humboldt County for the period 2007-2020 to be 1,313,500 bone-dry tons per year and includes forest thinnings, forest slash, and mill residues. The authors calculated this quantity of biomass could support about 225 MW of electricity generation capacity, which was the maximum capacity examined in the Humboldt RESCO study.

#### *2.2.1.4 Hydro*

There are currently six small hydroelectric facilities that serve Humboldt County (SERC, 2005). These facilities have a combined rated capacity of 11.5 MW. All but one of these, the Matthews Dam facility at Ruth Lake, are run-of-the-river systems. All of these systems are 5 MW or less in capacity and all of them sell power to PG&E via long-term contracts. One report identified numerous other sites totaling about 60 MW in capacity that have been identified for potential development (Oscar Larson & Associates, 1982). However, development of such projects would face numerous barriers, including strict environmental standards, rigorous permitting requirements, remote site locations, lack of transmission access, and lack of economic viability. Nonetheless, potential for expansion of small hydropower exists in Humboldt County. The study assumed a maximum potential capacity of 35 MW of small hydroelectric power.

#### **2.2.1.5 Solar**

Humboldt County is not well suited for large, utility-scale solar energy installations, including photovoltaic and concentrating solar thermal electric. The solar resource is not adequate to make such an installation economically viable, and there are few areas with large expanses of flat, available terrain. Most of the flat areas are in the foggy coastal parts of the county (near the Humboldt Bay and Eel River deltas), which are the population centers and agricultural centers. Consequently, this land is highly valued and not zoned for compatibility with large-scale solar farms.

Rooftop solar electric and solar hot water systems that serve individual facilities can be very appropriate in Humboldt County. On a per capita basis since 1998, the residents of Humboldt County have installed over twice as many grid-connected solar electric systems as the State of California as a whole. The total grid-connected capacity in 2010 was 1.44 MW from 428 systems (California Energy Commission, 2010a).

The average solar resource in the coastal areas of Humboldt County is 4.4 kWh/m<sup>2</sup>/day for a surface sloped at latitude (41°) and facing due south. The study assumed a maximum cumulative solar electric system capacity of 10 MW. The authors assumed that this capacity would come from small- to medium-sized distributed energy systems.

#### **2.2.1.6 Natural Gas**

There are natural gas deposits in Humboldt County in the Eel River basin. As of 2013 there were 40 active wells and 16 idle wells in the Grizzly Bluff and Tompkins Hill fields, with Tompkins Hill being the primary producer. Total net gas production in the county in 2010 was 786,279 thousand cubic feet (MCF). This was enough gas to supply approximately 11 percent of Humboldt County's total natural gas needs that year. The peak production for the Tompkins Hill field has passed. Current production rates are only about 20 percent of what they were when peak production reached over 3,000,000 MCF in the mid-1980s (California Department of Conservation, 2013). There were 10 new exploratory wells drilled in recent years in the Alton area where there are two new producing wells (Wheeler, 2005). The size of the natural gas reservoir in the Alton area is still unknown and data being collected is proprietary. All of the active gas wells in Humboldt County are dry gas wells and are not associated with oil deposits.

A gas transmission pipeline also supplies natural gas to Humboldt County as discussed in Section 1.5.4.

#### **2.2.1.7 Biogas**

Additional sources of biomass-based fuel in Humboldt County include biogas from numerous resources. Among these are digester gas from wastewater treatment plants and/or food waste digesters, landfill gas, and dairy biogas. These projects are not likely to make a large contribution toward meeting the county's electricity needs, as the power production from all of these sources combined is unlikely to be more than about 1 MW in the best of circumstances. Nonetheless, these projects are likely to be small-scale community based efforts that will have strong local support and offer substantial local benefit. As such, they represent some good potential near-term projects for the Humboldt RESCO strategic plan.

A food waste digester project currently being proposed by the Humboldt Waste Management Authority could generate up to 300 kW (Humboldt Waste Management Authority, 2010). The project would involve the creation of a local food waste collection program. Food waste would be digested adjacent to the Eureka wastewater treatment plant facility and digester gas would be added to the wastewater treatment plant's digester gas stream. In addition to renewable energy generation, project benefits would include a reduction in the solid waste stream, monetary savings, and GHG reductions.

Humboldt Waste Management Authority has also considered a landfill gas to energy project at the Cummings Road Landfill. The facility is equipped with a gas collection system as required by law, but the gas is currently being flared. Several options have been explored for converting the landfill gas from the Cummings Road facility to a marketable energy product. As the landfill is currently undergoing earthworks operations as part of the final closure process with expected completion by the end of 2013, energy development is temporarily on hold. Humboldt Waste Management Authority will perform monitoring to determine post closure gas production rates and will analyze the technical and economic feasibility of energy project development.

Regarding power generated from anaerobic digester gas from wastewater treatment plants, Humboldt County has four facilities that may be large enough to justify electrical power generators (SERC, 2005). The Eureka wastewater treatment plant already operates a 95 kW generator powered by anaerobic digester gas. Three additional wastewater treatment plants offer power production potential of 20 to 30 kW each and include plants for the cities of Arcata, Fortuna and McKinleyville. Economic feasibility for each of these facilities is uncertain; their small size makes it challenging to find suitable and cost-effective equipment.

Finally, power generation from dairy biogas does not appear particularly promising for Humboldt County dairies because of their small size and pasture-based operations (Reis and Engel, 2003). If biogas digester systems were installed on individual dairies the typical generator size would likely be about 25 kW. There have been discussions about regional facilities that would combine waste from multiple dairies. While the viability of these larger systems might still be challenging, there are also water quality and environmental regulations that must be met, and centralized manure management systems could potentially help address this need.

Note that the project team did not consider these various biogas resources in the modeling exercise due to their small cumulative capacity.

#### **2.2.1.8 Heating Fuels**

Heating fuels in Humboldt County predominantly include natural gas (discussed in Section 2.2.1.6), propane, and firewood. All propane is trucked into the County. It has been estimated that firewood and propane account for about 15 percent of the energy used for space heating, water heating, and cooking in Humboldt County (SERC, 2005).

### **2.2.1.9 Transportation Fuels**

Essentially all transportation fuels are in the form of diesel and gasoline and are imported into the county, primarily via barge to the Chevron petroleum terminal at the south end of Eureka. A small amount of petroleum fuel is also trucked into the county, and a very small amount of biodiesel is produced locally from waste grease and oils. With respect to the energy balance model discussed below (Section 2.2.3), the analysis considered only gasoline for light duty vehicle applications.

## **2.2.2 Energy Technology Options**

Various energy technologies can be employed to help enable the effective use of renewable energy resources and enhance their benefits. Energy storage can be used to buffer intermittent renewables, and demand response and smart appliance technologies can help match energy demands to variable, intermittent supplies. In addition, plug-in electric vehicles and heat pumps can allow fuel switching from fossil fuels to local renewable electricity sources to serve the transportation and heating sectors. Use of these technologies can provide GHG emission reductions and other localized benefits. This section identifies and describes various energy technology options that the Humboldt RESCO study team considered.

### **2.2.2.1 Energy Storage**

A significant challenge to achieving high penetrations of renewable energy on the electric grid can be the variable and intermittent nature of some renewable resources. For example, solar and wind energy cannot be dispatched to match fluctuating demands, but instead must be used when available. A mismatch between the availability of these resources and the demand for electricity can result in supply deficits or surpluses that cannot be used. Energy storage provides a solution to this issue by decoupling the timing of resource availability from resource use, allowing electric power to be stored and released when needed.

The RESCO study examined the value of energy storage technologies being added to the Humboldt area grid. The team considered pumped hydroelectric energy storage, compressed air energy storage (CAES) and battery energy storage technologies. The simulation model considered a small pumped hydro storage facility with the following characteristics: maximum charge/discharge capacity of 25 MW, a maximum energy storage capacity of 18 GWh (enough energy to discharge for 30 days), and a cost of \$1.25 million/MW of capacity.

### **2.2.2.2 Fuel Switching – Transportation**

#### *Electric Vehicles*

Electric drive vehicles represent a fuel switching option that can reduce GHG emissions and allow greater use of local renewable energy resources. The team assessed the potential impacts of electric vehicles (EVs) in Humboldt County. The authors considered only light duty conventional vehicles (vehicles classified as autos or light trucks by the California Department of Motor Vehicles) fueled by gasoline for replacement by electric vehicles. Key tasks included establishing a baseline, projecting the future adoption of electric vehicles, characterizing vehicle performance and costs, and estimating vehicle charging power requirements. Based on EV

penetration estimates from two studies (EPRI/NRDC 2007 and ETEC 2010), the authors applied a maximum cumulative electric vehicle penetration of 38 percent for the year 2030.

### *Hydrogen Vehicles*

Another way of meeting transportation energy demands with local renewable energy resources is to produce hydrogen fuel. A likely hydrogen production pathway would be water electrolysis utilizing local renewable electricity. This fuel could then be most efficiently used in hydrogen fuel cell vehicles. Hydrogen fuel cell vehicles are currently poised for limited commercial introduction in the United States, with many of the major automobile manufacturers (for example, Daimler, General Motors, Honda, Hyundai, Nissan and Toyota) planning to offer commercial fuel cell vehicles in the 2015 to 2017 time frame.

This hydrogen fuel pathway would directly compete with the electric vehicle pathway, as local renewable electricity could be used to either charge electric vehicle battery packs or produce hydrogen. In this regard, EVs have numerous advantages over hydrogen fuel cell vehicles. EVs are currently becoming widely commercially available. EVs are likely to be cheaper than hydrogen fuel cell vehicles, at least in the near term. EVs make more efficient use of the available renewable electricity (plug-to-wheel efficiency for a modern EV, like the Nissan Leaf, is likely to be about 0.24 kWh/mi compared to a hydrogen fuel cell vehicle running on electrolytic hydrogen at 1.0 kWh/mi.) And finally, the infrastructure requirements for hydrogen production and fueling are likely to be somewhat more demanding than the required electrical system infrastructure upgrades required to support EVs. For all of these reasons, light duty hydrogen fuel cell vehicles were not considered in the Humboldt RESCO analysis.

There are, however, market niches where hydrogen fuel cell vehicles may out-compete EVs. These include vehicle applications that demand long distance driving. For example, the state-of-the-art Toyota Highlander Fuel Cell Hybrid Vehicle advanced (FCHV-adv.) has a range of up to 400 miles compared to the state-of-the-art Nissan Leaf battery electric vehicle (BEV) with a maximum range of only 100 miles. In addition, fuel cell vehicles can be refueled in a few minutes rather than the hours that are required in most cases to fully charge an EV battery.

Furthermore, fuel cell vehicles outperform EVs in heavy-duty vehicle applications, like transit buses. All-electric vehicles are not being proposed for full-size transit applications, whereas hydrogen fuel cell buses are being successfully used in these applications. The Humboldt RESCO study did examine the use of hydrogen fuel cell powered transit buses.

### *Forest-based Biofuels*

Humboldt County has a tremendous forest biomass energy resource. Currently a large portion of this resource is used to fuel wood-fired steam power plants, thereby generating electricity. If the use of this resource were expanded, a portion of the added electricity could be used to charge electric vehicles. However, an alternate pathway for using forest biomass energy resources to power the transportation sector would be to produce forest-based biofuels. Two forest-based biofuel options are cellulosic ethanol and Fischer-Tropsch biodiesel. These alternate pathways were explored and compared with the biopower to electric vehicle pathway

in terms of energy efficiency and GHG emissions using the Greenhouse Gases, Regulated Emissions, and Energy Use in Transportation (GREET) Model.

### **2.2.2.3 Fuel Switching – Heating**

Another area where fuel switching can be used to substitute local renewable energy sources for imported fossil fuels is in the heating sector. According to the U.S. Census (2000), 62 percent of households in Humboldt used natural gas for heating, 18 percent used wood, 10 percent used electricity (essentially all electric resistance heating), and 8 percent used propane. With large-scale renewable electricity development in Humboldt County, a portion of this heating energy demand could be served using renewable electricity and electric heat pumps. Consistent with the electric vehicle penetration estimates, the team evaluated a maximum cumulative heat pump penetration level of 38 percent. The authors considered heat pumps for both water and space heating applications to replace natural gas fueled heaters in the residential and commercial sectors.

### **2.2.2.4 Energy Efficiency**

Improvements in energy efficiency can substantially reduce energy demand. While there are no detailed Humboldt County-specific estimates of energy efficiency potential and associated costs, there is a wealth of literature at the state level. The most recent and authoritative of these reports available when the Humboldt RESCO analysis was performed was the *California Energy Efficiency Potential Study* by Itron, Inc. (2008).

The Itron study quantified yearly (2007-2026) energy savings potential and associated costs by investor-owned utility service territory, Energy Commission climate zone, consumption sector, building type, end-use category, fuel type (electricity or natural gas), and efficiency measure type. The Itron study assessed statewide technical, economic, and market potential for energy efficiency measures.

The Humboldt RESCO study considered only market potential and examined a range of incentive levels, starting with a base incentive and increasing up to the full measure cost. The project team scaled total savings potential from the statewide study to Humboldt County with adjustments for climate zone, population, and total county energy consumption. The maximum savings potential considered amounted to about a 25 percent reduction in energy consumption due to adoption of energy efficiency measures. It is important to note that the Itron study considered only existing, readily available, cost-effective energy efficient technologies. Because of this, the energy efficiency savings estimates can be considered conservative. Most assuredly there will be technological advances that push the potential savings associated with energy efficiency measures even further.

### **2.2.2.5 Demand Response**

Smart grid technologies can provide for two-way communication over the electrical grid, thereby allowing for control of appliances at customers' homes and businesses. Smart grid technology will be critical to allow intermittent renewable energy resources to charge electric vehicles, generate hydrogen fuel for vehicles, and charge heat pump thermal storage systems at the optimal times. As such, smart grid technology can play a significant role in the context of

Humboldt County's renewable energy future. As of March 2012, PG&E had installed almost 98,000 electric and gas smart meters in Humboldt County, which accounts for 89 percent of eligible meters (PG&E, 2012).

Installation of smart meters is just the first step in building the smart grid. By 2030 the smart grid will likely provide mechanisms to induce consumers (residential, business, and industrial) to curtail or shift electricity demand at critical times based on price signals. PG&E is currently transitioning all non-residential customers to time-varying pricing, and this trend is likely to continue. Based on a range of peak demand reduction estimates from the literature (Zoellick et al., 2012), the authors assumed a maximum of 10 percent load curtailment and 6 percent load shifting in this analysis.

#### *2.2.2.6 Upgrades to Electrical Transmission System*

One alternative for enabling large-scale development of renewable energy resources in Humboldt County may be to upgrade the capacity of the transmission lines that serve the county, thereby allowing excess renewable power to serve loads in other geographic regions of the state. This could improve the technical and economic viability of large-scale renewable energy development in the county. As noted in section 1.5.4, current transmission infrastructure includes two key 115 kV lines from Cottonwood east of Humboldt County. The combined thermal limit to the export (or import) of power over these circuits is 80 MVA to 167 MVA. The range of limits is due to a combination of real-time factors such as weather and congestion outside of Humboldt. In addition, the power factor over the system is less than unity, which means that the exportable real power is less than the capacity of the lines. Furthermore, there must be redundancies in the system to ensure reliable operation of the Humboldt area grid. Accurately estimating all of these factors at the hourly time resolution of the energy balance model was beyond the scope of this study. The authors therefore made the conservative assumption that there is currently a 60 MW limit to the real power that can be exported or imported from/to Humboldt County during any hour of the year. Consultation with PG&E staff has confirmed that a normal operating capacity of 60-70 MW is reasonable. The authors considered an expansion of transmission capacity serving Humboldt County of up to 250 MW.

#### *2.2.2.7 Distributed Generation and Combined Heat and Power*

Distributed generation has been defined by the Energy Commission as electricity production at a capacity of 20 MW or less that is on-site or close to a load center and is interconnected to the utility distribution system (California Energy Commission, 2007). Typical distributed generation technologies include photovoltaics, small wind, small biomass, and small combined heat and power (CHP) systems. The Humboldt RESCO optimization analysis considered distributed photovoltaics, along with small biomass and small hydro.

The authors did not consider combined heat and power opportunities in the modeling exercise; however, they are included in the strategic plan and the authors recommend they be studied further. Prime opportunities for CHP include commercial and industrial applications where a substantial and steady source of thermal energy is required. These include hospitals, jails,

colleges, large office buildings, casinos, supermarkets, and commercial and industrial processes. CHP systems are typically sized to meet the heating load.

Also, regardless of whether distributed generation opportunities in Humboldt County can meet a large portion of the local electrical demand, distributed generation can play an important role in Humboldt County's RESCO plan. Small, distributed projects are one key way that local residents and businesses can directly participate in implementing the RESCO vision. This can play an important role in building community support for the goals of the greater community, and therefore is expected to be an important part of the Humboldt County RESCO strategic plan implementation.

#### **2.2.2.8 *Natural Gas-Fired Power Plant***

In September of 2010, PG&E began operation of the HBGS. This facility replaced two 50 MW Rankine cycle steam electric generators that were installed in the late 1950's, and two 15 MW diesel powered gas turbine generators. The new plant consists of ten 16.3 MW natural gas-fired simple cycle engine generators made by Wartsila. The new generators have an overall thermal efficiency rating of approximately 45 percent (a 33% increase over the old steam electric generators), are able to be operated individually, and are capable of closely following changes in demand and supply. They are capable of ramping up from a warm standby state to full power in 10 minutes. The authors assumed in this analysis that the generators can provide all of the local reserve capacity that is needed for the Humboldt Area.

### **2.2.3 Energy Balance Model Methodology**

The Regional Energy Planning Optimization (REPOP) Model includes an energy balance model and an optimization algorithm that can identify the best mix of resources. The model tracks Humboldt County's energy flows for the electricity, heating, and transportation (light duty vehicles only) sectors. The energy balance model is made up of a combination of submodels that characterize supply and demand for energy, an algorithm that dispatches supply to meet demand, and post processing algorithms that serve to summarize a model run. Figure 2.2 depicts how these algorithms work together to model energy production and consumption. A portfolio of generation capacities and demand levels is defined as input to the model. Outputs from the model summarize the resulting energy costs, GHG emissions, economic impacts, and service quality associated with a given portfolio over an annual cycle.

**Figure 2.2: Regional Energy Planning Optimization Model**

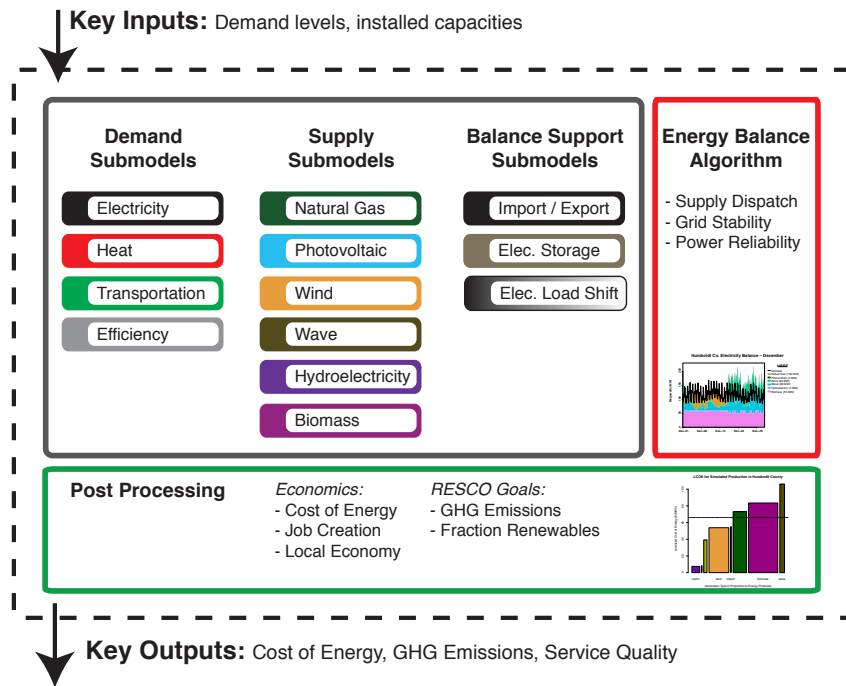

Source: Schatz Energy Research Center.

Key characteristics of the model are as follows. Electricity supply is modeled on an hourly basis. Electricity demand is also assessed hourly, with demand for heat and transportation fuels (for example, gasoline, natural gas, propane and wood for heating) assessed daily. Demand is forecasted ahead to the year 2030 based on population growth projections. Key data sources used to estimate the availability of energy supply resources and energy demands are listed in Section 2.2.4. The model includes a stochastic element to reflect the variability in supply and demand.

The model is capable of evaluating opportunities for fuel switching, where liquid or gaseous fossil fuels are replaced by electrical energy to supply heating and transportation energy demands. The model also considers energy efficiency and demand response opportunities. Electrical energy storage technologies can be modeled and electricity reserve capacity requirements are accounted for using a persistence forecasting method.

The model is used to assess various energy supply portfolios. Key outputs include the cost and GHG emissions associated with a particular portfolio, as well as the percentage of local energy demand supplied by local renewable resources. The modelers used an optimization algorithm to identify optimal resource portfolios that minimize GHG emissions at a fixed cost. Table 2.1 shows the range of parameters explored with the REPOP model in the optimization exercise. Note that the lower limit is used as the default value for the base case, or “business-as-usual” scenario.

**Table 2.1: Decision Variables Used in the Optimizations  
and Their Corresponding Boundary Constraints**

<b>Decision Variable</b>	<b>Lower / Upper Limit of Installed Capacity (includes existing and new capacity)</b>
Wind Capacity (MW)	0 / 250
Wave Capacity (MW)	0 / 100
Biomass Capacity (MW)	61 / 225
Hydropower Capacity (MW)	10.4 / 35
Solar PV Capacity (MW)	1.1 / 10
Import/Export Transmission Capacity (MW)	60 / 250
Storage Capacity (MW)	0 / 25
Efficiency Program Level (0 = Base incentive, 100 = Full measure cost incentive)	0 / 100
Electric Vehicle Penetration (% of registered vehicles)	0 / 38
Heat Pump Penetration (% of residential & commercial natural gas furnaces)	0 / 38
Demand Response (% of max potential or approximately 12% of peak load)	0 / 100

Source: Schatz Energy Research Center.

## 2.2.4 Key Data Sources

The authors used local wind, wave, and solar energy data to model potential renewable energy supplies in Humboldt County. The team used actual measured data where available and modeled data when necessary (for example, for the wind resource). The authors based energy production estimates on available resource data and real-world power conversion and capacity factor estimates. The team obtained historical power generation data for existing biomass fired power plants and some hydropower stations. PG&E and the Energy Commission provided electricity consumption and demand data. Tables 2.2 and 2.3 document key data used in the analysis. Additional information on data sources can be found in *Humboldt County Renewable Energy Secure Community: Resource and Technology Assessment Report* (Zoellick et al., 2012).

**Table 2.2: Energy Resource Data Sources**

Resource	Location	Data Sources	Time Scale	Period of Record
Wind resource	Bear River Ridge	NREL Western Wind Resources Dataset (NREL, 2010a)	hourly	3 years
Wave resource	South Spit Humboldt Bay	NOAA Buoy 46022 (NOAA, 2010)	10-minute interval	9 years
Solar resource	Arcata	National Solar Radiation Database (NREL, 2010b)	hourly	15 years
River hydro resource	various	Humboldt Bay Municipal Water District (HBMWD, 2010), Three Forks Water Power Project (Burgess, 2010), USGS Mad River flow data (USGS, 2010), Alderpoint precipitation data (Western Regional Climate Center, 2010)	varied	varied
Biomass power plant	Fairhaven	DG Fairhaven Power (Marino, 2010)	daily	1 year

Source: Schatz Energy Research Center.

**Table 2.3: Electricity and Natural Gas Demand Data Sources**

Data Type	Segregation	Time Scale	Duration	Source
Electricity Use (kWh)	Countywide	15-minute	2004-2009	PG&E, 2010
Electricity Use (kWh)	Resid/Comm/Industrial & Commercial Bldg Type	Monthly	2004-2008	Energy Commission, 2010b
Electric Customer Counts	Resid/Comm/Industrial & Commercial Bldg Type	Annual	2004-2008	Energy Commission, 2010b
Natural Gas Use (therms)	Resid/Comm/Industrial & Commercial Bldg Type	Monthly	2004-2008	Energy Commission, 2010b
Natural Gas Customer Counts	Resid/Comm/Industrial & Commercial Bldg Type	Annual	2004-2008	Energy Commission, 2010b

Source: Schatz Energy Research Center.

### 2.2.5 Interconnection Feasibility Study

Simulations using the REPOP model identified opportunities for substantial development of renewable energy projects on the Humboldt Area electric grid. Before any new generators are added to the grid, however, interconnection studies will need to be performed to identify required transmission and distribution system upgrades. To develop a preliminary assessment

of the need for infrastructure upgrades, the Humboldt RESCO study engaged the services of project partner and local investor-owned utility PG&E.

PG&E’s Interconnected Grid Planning group conducted an interconnection feasibility study to evaluate the transmission impacts of a representative scenario for future renewable energy development in Humboldt County. The objectives of the study were to identify:

- Transmission system impacts caused solely by the addition of the proposed renewable energy development
- System reinforcements necessary to mitigate any adverse impacts of the proposed renewable energy development under various system conditions
- Facilities required for system reinforcements with a non-binding good faith estimate of cost responsibility

The study examined transmission facilities within PG&E’s Humboldt and North Coast Areas. The study assumed a projected year 2030 winter peak electric loading condition of 223 MW and included nine proposed new generation facilities in Humboldt County with a total generation output of 253 MW. Table 2.4 lists the proposed new generation facilities, their locations, and their proposed points of interconnection, while Figure 2.3 shows the geographic dispersion of these facilities.

**Table 2.4: New Generation Sources Considered in Interconnection Feasibility Study**

<b>Technology</b>	<b>Max MW</b>	<b>Location Description</b>	<b>Proposed Point of Interconnection</b>
Wind	50	Bear River Ridge	Rio Dell Substation 60 kV Bus
Wind	75	Bear River Ridge	Rio Dell Substation 60 kV Bus
Biomass	40	Samoa	Fairhaven Substation 60 kV Bus
Biomass	15	Willow Creek	Willow Creek Substation 60 kV Bus
Biomass	15	Garberville	Garberville Substation 60 kV Bus
Hydro	8	Maple Creek	Maple Creek Substation 60 kV Bus
Hydro	5	Hoopa Valley	Hoopa Substation 60 kV Bus
Storage – Pumped Hydro	15	Ruth Lake	Low Gap Substation 115 kV Bus
Wave	30	Samoa	Fairhaven Substation 60 kV Bus
<b>Total</b>	<b>253</b>		

Source: PG&E, 2011a.

**Figure 2.3: Locations of New Generation Facilities and Interconnection Points**

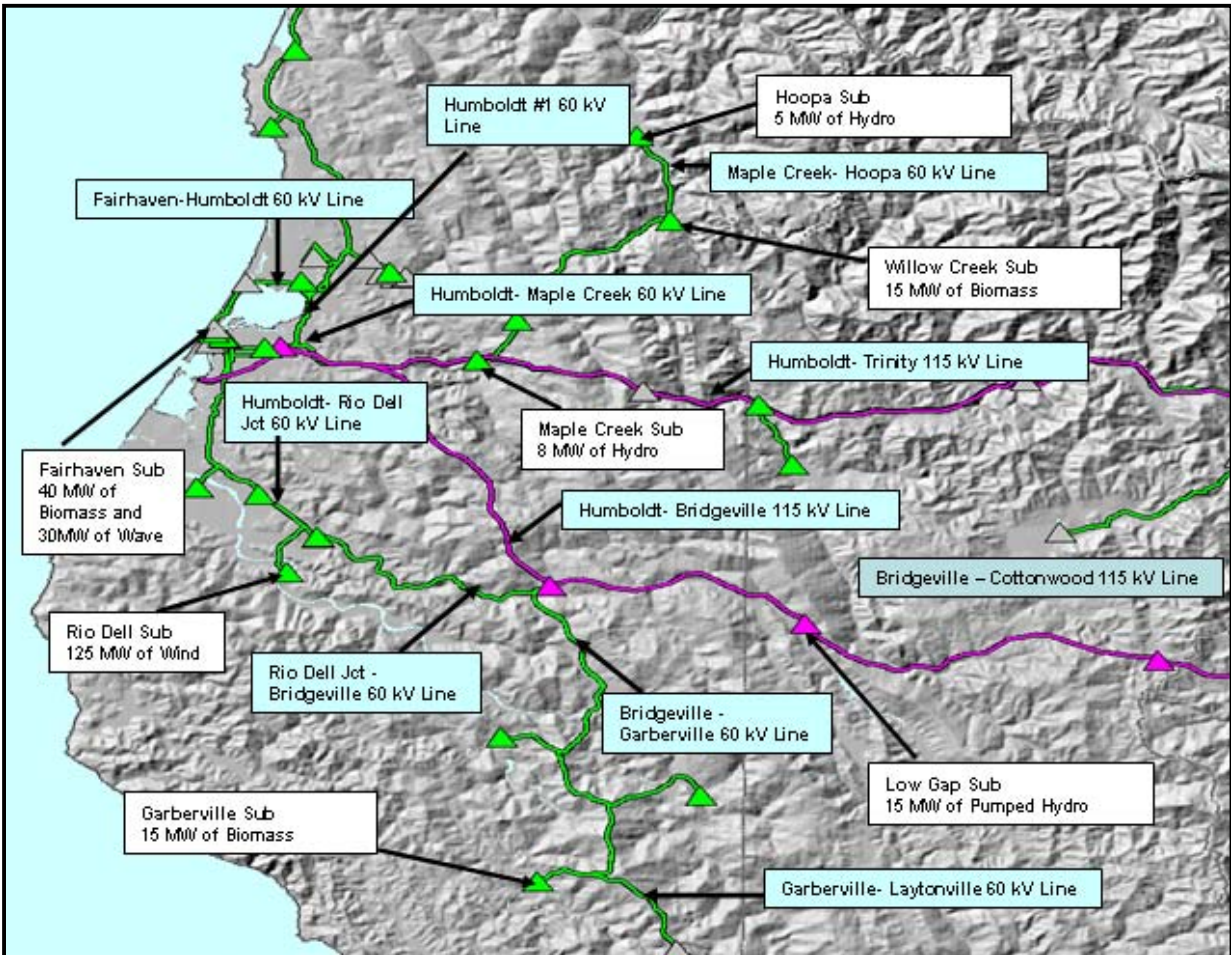

Source: PG&E, 2011a.

The interconnection study was performed to ensure that PG&E’s transmission system remains in full compliance with North American Electric Reliability Corporation (NERC) reliability standards. Two power flow base cases were used in the analysis. These included a winter peak base case and an off-peak base case, representing extreme loading and extreme generation conditions, respectively. Additional analyses were not possible within the scope of the Humboldt RESCO study. Consequently, it is important to note that this was a preliminary analysis, and the results of this study do not provide any guarantees about the ability of the system to function properly during times, seasons, and situations not studied.

### 2.2.6 Hydrogen Fueled Transit Assessment

The Humboldt RESCO study examined the use of hydrogen fuel cell powered transit buses. The analysis was independent of the REPOP modeling exercise. The analysis considered the development of hydrogen infrastructure capable of handling 10 percent to 100 percent of transit needs and examined the resulting cost and GHG emission implications. The authors assumed that hydrogen fuel would be generated via electrolysis powered by local grid electricity.

## 2.2.7 Forest-based Biofuels Assessment

There are two primary alternatives for utilizing the forest biomass resource in Humboldt County to power vehicles: (1) combustion of biomass for electricity generation to power electric vehicles and (2) production of biofuels through biochemical, thermochemical, and Fischer-Tropsch conversion processes. Based on these two alternatives, the team developed and assessed five related fuel pathways (Table 2.5) using the Greenhouse Gases, Regulated Emissions, and Energy Use in Transportation (GREET) Model. The modelers also developed well-to-wheels estimates of fossil fuel consumption and GHG emissions. The analysis was independent of the REPOP modeling exercise.

**Table 2.5: Description of Fuel Pathways Modeled in GREET**

Fuel Pathway	Description
Baseline: CG and RFG for CVs	Conventional gasoline (CG) and reformulated gasoline (RFG) are used to fuel spark ignition conventional vehicles (CVs)
E85 (gasification) for FFVs	A gasification based process is used to produce ethanol (E85) from forest biomass; ethanol is used to fuel spark ignition flex-fuel vehicles (FFVs)
E85 (fermentation) for FFVs	A fermentation based process is used to produce ethanol from forest biomass; ethanol is used to fuel spark ignition flex-fuel vehicles
FTD100 for CIDIVs	The Fischer-Tropsch process is used to produce Fischer-Tropsch Diesel (FTD) from forest biomass; FTD is used to power compression-ignition direct-injection vehicles (CIDIVs)
CG/RFG and Electricity for SI PHEVs	Conventional/reformulated gasoline and electricity from the combustion of forest biomass are used to power spark ignition (SI) plug-in hybrid electric vehicles (PHEVs)
Electricity for BEVs	Electricity from the combustion of forest biomass is used to power battery electric vehicles (BEVs)

Source: Schatz Energy Research Center.

## 2.3 Development, Financing, and Ownership Options

There are many possible models for the development, financing and ownership of renewable energy projects. The project team identified and researched a set of models and assessed their potential to help implement the Humboldt RESCO vision. In particular, the various options can affect (1) the community's ability to implement the RESCO vision, (2) the benefits accrued by the local community from local renewable energy projects and programs, and (3) the potential risks associated with project and program development.

The development, financing, and ownership options considered are listed below.

### Development/Ownership Models

- Investor-owned utility (IOU)
- Independent power producer (IPP)
- Public power – Community Choice Aggregation and municipal utilities
- Community renewable energy models and public/private partnerships

## Financing Options for Renewable Energy Generation

- Equity financing
- Loan financing
- Bond financing
- Community renewable energy, flip structures
- Grants, rebates, and tax credits
- Environmental assets
- Residential and small commercial financing

## 2.4 Economic Analysis

The team assessed the costs and economic impacts associated with a renewable energy development plan for Humboldt County. The economic analysis is described briefly below. Further detail is provided in the *Humboldt County as a Renewable Energy Secure Community: Economic Analysis Report* (Hackett et al. 2012).

The cost analysis examined the construction, operation, and maintenance costs associated with each renewable energy category (biomass, wind, wave, small hydroelectric, and solar photovoltaic) as compared to the costs of natural gas-fired generation at the HBGS. Additionally, the team estimated the costs of more aggressive energy efficiency programs and a transition from conventional heating and transportation technologies to heat pumps and electric vehicles. The team then used the results of the cost analysis as inputs to the REPOP Model discussed in Section 2.2.3.

The team also assessed the creation of jobs and economic activity that could be directly or indirectly attributed to new renewable energy development. The analysts specified a set of renewable energy development scenarios based on output from the REPOP model and employed a suite of economic impact assessment models to estimate the local jobs, income, and economic output generated due to the construction and operation of proposed renewable energy and energy efficiency projects.

### 2.4.1 Cost Analysis

Elements of the cost analysis included modeling and estimating the instant capital cost, levelized cost, and marginal cost of dispatch for each renewable energy resource, as well as for the existing gas-fired generation plant. The authors first drew cost estimates for natural gas-fired electricity generation, renewable electricity generation, energy efficiency, and heating and transportation fuels and technologies from the most current and authoritative literature. In addition to technology costs, the analysis included estimates of the cost per unit of avoided pollution emissions implied by renewable energy, energy efficiency, and electric vehicle investments. Based on the research team's knowledge of local conditions and extensive local interviews, they modified cost estimates to reflect unique conditions in Humboldt County.

## 2.4.2 Economic Impact Assessment

To evaluate economic development potential, the research team used highly specialized economic impact assessment models for each of the major renewable energy categories and for energy efficiency. For natural gas, wind, and solar photovoltaic generation, the research team customized available Jobs and Economic Development Impact (JEDI) models developed by the National Renewable Energy Laboratory (NREL, 2009). Models were unavailable, however, for biomass, wave, small hydroelectric, and energy efficiency. Consequently, the research team reverse engineered the available JEDI models and used that knowledge to develop their own impact assessment models for these technologies. By utilizing this full suite of models, the research team was able to estimate net economic impacts associated with renewable energy development in Humboldt County.

## 2.5 Regulatory and Political Issues

The regulatory and political environment can have a dramatic impact on the ability to develop and use local renewable energy resources. Accordingly, one goal of the project was to examine the regulatory and political landscape and assess its potential impact on the implementation of the RePower Humboldt Strategic Plan. The team developed two key deliverables: (1) a Regulatory and Policy Guide on Renewable Energy and Energy Efficiency for Humboldt County Local and Tribal Governments, and (2) a regulatory and political issues memo outlining the challenges associated with implementation of the RePower Humboldt Strategic Plan.

The Regulatory and Policy Guide is an action-oriented guide that provides local policy makers with resources and tools they can use to increase energy sustainability in their communities. A background section provides useful information about the energy industry, state energy policy, and the local energy scene. This sets a context for the action areas that follow. Each action area is organized in the following format: *The Opportunity* (background information and notes on the role local government can play), *The Local Angle* (what's already happening in Humboldt County, emphasizing unique local aspects), *Examples from Elsewhere* (brief case studies from outside the county), and *Resources* (where to get more information).

## 2.6 Stakeholder Analysis

One of the aims of the Humboldt RESCO project was to assess community goals, preferences, and perceived issues related to renewable energy development in Humboldt County via a stakeholder engagement process. This process consisted of a number of tasks. First, the project team identified a broad list of stakeholder groups along with prospective representatives from each group. Next, the team contacted stakeholders and invited them to participate in the Humboldt RESCO project. The stakeholder engagement process included two key stakeholder meetings, a separate youth stakeholder meeting, and a web-based survey for those who couldn't attend the meetings. In addition, the team sent the Draft RePower Humboldt Strategic Plan to each of the stakeholders for their review and input. In addition to these official stakeholder activities, there were a number of informal meetings and gatherings that occurred throughout the project, allowed for additional community input, and generally informed the strategic planning process.

### 2.6.1 Stakeholder Groups

The project team specified eleven stakeholder categories and recruited participants from each of these categories to participate in the stakeholder process. The team made a concerted effort to cast a wide net and recruit a broad cross section of the community. Table 2.6 lists the stakeholder categories, the number of stakeholders invited within each category, and the number of stakeholders that participated in the stakeholder meetings.

### 2.6.2 Stakeholder Meetings

The first stakeholder meeting was held on November 18, 2010. Key activities at the meeting were (1) the development of a vision statement for renewable energy development in Humboldt County, and (2) development and ranking of criteria for evaluating potential renewable energy projects. The stakeholders developed a RESCO vision statement based on an earlier sustainable energy vision statement that had been developed via a public process associated with the draft Energy Element for the Humboldt County General Plan Update.

Following the first stakeholder meeting, the team conducted a web-based survey to solicit input from those stakeholders who were not able to attend the meeting. The survey presented renewable energy project evaluation criteria, which had been developed by stakeholders at the first project meeting, and the survey asked participants to rank the criteria according to their importance. An additional 19 stakeholders participated in the web-based survey. The authors then combined results of the web-based survey with the ranked results from the first meeting to arrive at the final ranked evaluation criteria shown in Table 2.7.

Following the initial general stakeholder meeting, the team conducted a special youth stakeholder meeting. The authors recruited youth from local area high schools to participate, and a total of 35 youth attended the meeting. Meeting organizers engaged the youth in developing a vision for Humboldt County's energy future, as well as a set of project evaluation criteria. The criteria the youth came up with were similar to the criteria generated by the general stakeholder group. Youth also identified environmental quality as the most important criterion and ranked affordability as the number two criterion. Youth also ranked job creation and economic impacts as important criteria.

A final general stakeholder meeting was held on April 13, 2011. At this meeting, organizers presented stakeholders with a project update and a review of the work completed to date. Participants then broke into small groups to discuss seven different potential energy project categories. These included: biomass, wind, small hydro, electric vehicles, heat pumps and other efficiency technologies, and solar. Also discussed were potential energy projects being considered by the Humboldt Waste Management Authority, including solar electricity, landfill gas to energy, and food digester projects. Each group brainstormed potential near-term projects; identified key players; considered strengths, weaknesses, opportunities and threats; and identified near-term next steps and long-term goals and concerns.

Stakeholder input gathered as a result of these stakeholder activities helped inform the development of the RePower Humboldt Strategic Plan.

**Table 2.6: Stakeholder Participation in RePower Humboldt Meetings**

Stakeholder Group	Invited to Participate	Attended Meeting 1	Attended Meeting 2	Attended Youth Meeting
Business Community	5	3	2	
Economic Development/Financial Organizations	8	3	2	
Education/Policy Groups	6	2	2	
Energy Industry	9	8	4	
Environmental/Energy Groups	8	2	2	
Forestry and Fisheries Organizations	11	4	2	
Labor Groups	5	0	3	
Political Leaders	17	6	6	
Regulatory Bodies	9	3	1	
Tribes	8	0	1	
Youth	36	2	2	35
<b>Total</b>	<b>122</b>	<b>33</b>	<b>27</b>	<b>35</b>

Source: Schatz Energy Research Center.

**Table 2.7: Criteria for Evaluating Renewable Energy Projects**

Criteria	Ranked Score (out of 100 points total)
Environmental Quality	23%
Financial Viability / Affordability	22%
Local Acceptance, Participation, and Control	16%
Economic Impact (Jobs, Income)	13%
Appropriate Technology	13%
Social/Environmental Justice	8%
Other Community Benefits	4%

Source: Schatz Energy Research Center.

### 2.6.3 Additional Stakeholder Activities

In addition to the formal stakeholder activities listed above, there were a number of other stakeholder activities that occurred throughout the project timeframe. In general, if there were community meetings or local activities taking place related to energy development in Humboldt County, the RePower Humboldt Project Team tried to be present, both to share ideas and to hear from others in the community about their ideas on Humboldt County's energy future. Below is a partial list of informal activities the RePower Humboldt Project Team participated in.

- Scoping meeting and community meetings regarding the proposed Shell WindEnergy, Inc. Bear River Ridge Wind Project
- PG&E WaveConnect™ Humboldt Working Group meetings
- Energy discussion meetings with local environmental organizations (coordinated by the Northcoast Environmental Center)
- Blueprint Humboldt Advisory Committee meetings
- City of Arcata Energy Committee meetings
- Humboldt County General Plan Update meetings
- Meetings with Humboldt Waste Management Authority; Humboldt Bay Harbor, Recreation and Conservation District; Humboldt Bay Municipal Water District; Humboldt State University; Blue Lake Power; and Blue Lake Rancheria

## 2.7 Strategic Plan

The culminating task for the Humboldt RESCO project was the development of the RePower Humboldt Strategic Plan. All other tasks informed and/or led up to this culminating task. The RePower Humboldt strategic planning process was conducted over a three year four month period beginning in November of 2009. Figure 2.4 provides a diagram of the RePower Humboldt Strategic Planning process.

The resource and technology assessment, economic analysis, evaluation of development, financing and ownership models, and assessment of regulatory and political issues all provided critical input into the development of the strategic plan. In addition, stakeholder input helped shape the plan to reflect community values and preferences. Utilizing all of this information, the project team developed a draft RePower Humboldt Strategic Plan and publicly released it on September 18, 2012. The team held a town hall meeting on September 26, 2012 to share the results of the plan with the public and solicit input. The authors received public comment on the document through October 26, 2012 and made minor modifications to the plan based on the public input received. The authors completed a final version in March of 2013.

**Figure 2.4: RePower Humboldt Strategic Planning Process**



Source: Schatz Energy Research Center.

The plan sets a context by providing background information about Humboldt County’s energy characteristics. It also describes the strategic planning process and presents the vision statement and community values developed by the stakeholder group. Then it presents the results of the resource and technology assessment and economic analysis. The plan uses three representative scenarios, *business-as-usual*, *bold*, and *peak*, to illustrate what is possible. Both the *bold* and *peak* scenarios are consistent with the vision statement and community values developed by the stakeholder group. However, these two scenarios differ in their emphasis, with the *peak* scenario emphasizing greater renewable energy development and associated reductions in GHG emissions, while the *bold* scenario strives to keep costs down with more moderate achievement of renewable energy goals.

Rather than stressing a specific path forward, the strategic plan lays out a range of options that can move the community forward. This includes a set of long-term strategies and associated near-term next steps. The plan summarizes near-term next steps, or implementation measures, in tabular form with a list of responsible parties, a proposed schedule of action, and notes about potential funding and other related resources. The RePower Humboldt Strategic Plan is a “living document” that can evolve over time. This flexibility has helped the plan to gain broad support in the community.

## 2.8 Community Outreach

As part of the RePower Humboldt project, the authors developed a community outreach and education plan. The plan is meant to serve as a guide for activities that will further engage the community. Broad public support, participation and commitment are essential to successful implementation of the Strategic Plan and the project team identified them as key parts of the long-term strategy for achieving the RePower Humboldt vision.

In addition to the development of an education and outreach plan, the RePower Humboldt project team engaged in education and outreach activities throughout the project period to spread the word and garner public support. These activities included: a town hall meeting to present the RePower Humboldt Strategic Plan to the general public, a 30-minute energy roundtable discussion on public television (KEET-TV) called *Blueprint Humboldt: Renewable Energy*, numerous radio interviews, articles and editorials in local newspapers and community group newsletters, and many presentations delivered at local conferences and to community groups and college classes.

Outreach materials developed in support of the project included numerous PowerPoint presentations and a professionally published RePower Humboldt Strategic Plan document. The strategic plan document also included an eight-page Executive Summary version in a brochure-like format, which made the information easily accessible to a general lay audience. Also, the team developed a RePower Humboldt web page that describes the RePower Humboldt project, provides links to all available project documents, and keeps the public informed of upcoming activities. This web page is integrated into the Redwood Coast Energy Authority's main website and will be an ongoing, maintained feature. RCEA's website is the "go to" website for energy information in the region, and it will provide a long-term presence for disseminating RePower Humboldt program information.

Finally, the team developed an electronic mailing list to keep people informed about RePower Humboldt activities and events. This mailing list includes e-mail addresses for invited RePower Humboldt stakeholders, as well as for any interested community members who requested to be kept informed of project activities.

## 2.9 RESCO Planning Workbook

The RESCO planning workbook chronicles Humboldt County's RePower Humboldt strategic planning process. The workbook will allow other communities to learn from Humboldt County's experience and employ similar strategic planning methods in their pursuit of RESCO status. The RESCO Planning Workbook provides an overview of the planning process and discusses each of the key project tasks. For each task, the workbook provides information about the goals and objectives of the task, particular actions taken, data or information resources used, task deliverables, and lessons learned. In addition, the workbook includes a listing of titles of all documents generated as part of the project with a URL link for online access to the documents.

# CHAPTER 3:

## Project Outcomes

### 3.1 Resource and Technology Assessment

#### 3.1.1 Energy Modeling Results

The team used the Regional Energy Planning Optimization (REPOP) Model to simulate energy supply and demand scenarios for the year 2030. Results from these simulations were instrumental in developing the RePower Humboldt Strategic Plan. This section summarizes the energy modeling results. For a more detailed discussion see the *Humboldt County Renewable Energy Secure Community: Resource and Technology Assessment Report* (Zoellick et al. 2012).

As discussed in Section 2.2.3, the REPOP model simulates electricity supply and demand on an hourly time interval. Figure 3.1 shows hourly model results for one week in November for one supply scenario. The capacities of installed electricity generation resources are listed in the legend on the right of the figure. The solid black line denotes the hourly electrical demand. In this example, biomass and hydropower are run essentially as baseload supply resources. Wind, wave, and solar PV are supplied as available, and the natural gas plant (PG&E's HBGS) is used for load following. At times there is excess supply that theoretically would be exported out of the Humboldt area via the 60 MW transmission line that ties into the larger California grid in the Central Valley at Cottonwood. If excess power were produced that could not be exported (that is, greater than 60 MW), then that power would either be curtailed or local energy storage would need to be employed.

The REPOP model explored both of these situations. In general the model showed that the amount of "spillage," or excess power that could not be exported, was typically very low (< 1 percent of total power generated) unless the capacity of intermittent renewable electricity generators (like wind and wave power) became large (> 150 MW), which was uncommon. In these cases local energy storage could become an important enabling technology.

##### 3.1.1.1 REPOP Model Optimization

For any given scenario, the team ran the REPOP model for a full 8760 hours (one year) and summary results were generated, including total cost of energy, GHG emissions, and percentage of demand supplied with local renewable energy. Given a cost constraint, the decision variables shown in Table 2.1 could be adjusted until the GHG emissions were minimized. In this fashion the modelers conducted a series of optimization runs to produce the optimality curve in Figure 3.2. The curve represents the emissions reductions achievable at a given cost and is referred to as Curve C (Curve C indicates a maximum penetration for PEVs and heat pumps of 38 percent; see Section 3.1.1.2 for further explanation).

Figure 3.1: Example Hourly Supply and Demand Profile from REPOP Model

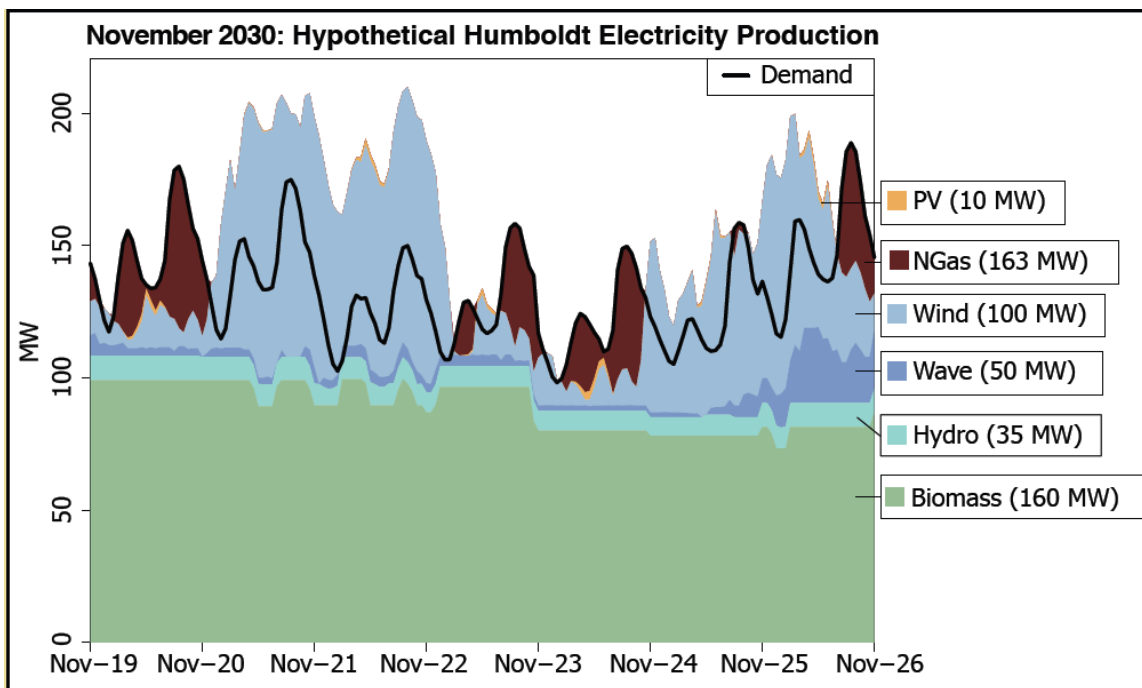

Source: Schatz Energy Research Center.

The red triangle in Figure 3.2 shows the business-as-usual (BAU) scenario. In this case, the existing infrastructure is used to meet energy demand (that is, the lower bounds are used for all decision variables shown in Table 2.1). As can be seen, the BAU scenario is not optimal. In fact, adjustments in the energy supply portfolio can reduce GHG emissions while simultaneously lowering costs. The leftmost point on the curve indicates that a 9 percent reduction in GHG emissions is possible with a 1 percent decrease in costs below business-as-usual. This is because there is substantial opportunity to implement energy efficiency measures that are cheaper than competing supply options.

As costs increase, more and more emissions reductions are achievable, but with decreasing returns on investment. The dashed black line indicates the limit for reduced emissions. This represents the result of an optimization where emissions were minimized with no cost constraint, and therefore represents the technical limit to reducing emissions given the decision variable constraints in Table 2.1. With a 38 percent penetration rate of PEVs and heat pumps, the maximum decrease in GHG emissions, irrespective of cost, is about 45 percent below business-as-usual. The dashed blue line represents 1990 GHG emission levels, and the dashed green line represents an 80 percent reduction in GHG emissions below 1990 levels, which is the State of California’s goal for GHG reductions by 2050.

**Figure 3.2: Optimality Curve (Curve C) - Minimize Emissions with Various Cost Ceilings**

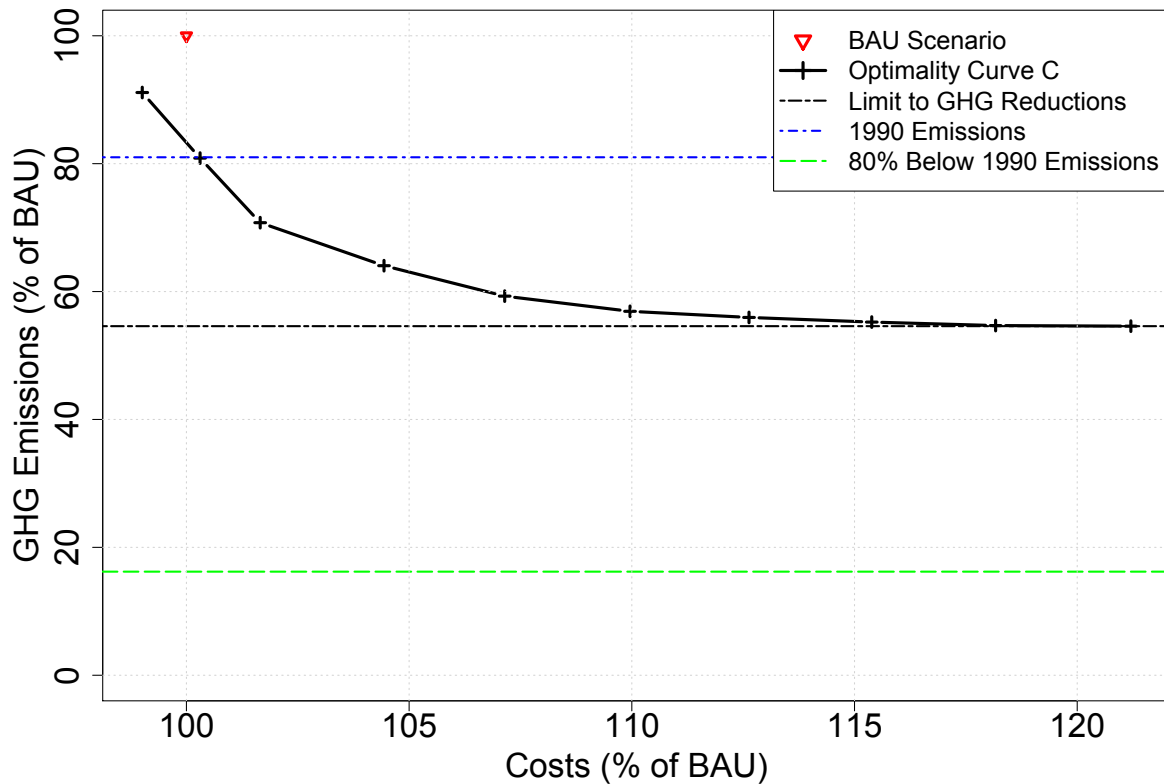

BAU stands for business-as-usual.

Source: Schatz Energy Research Center.

The optimal scenarios associated with a subset of the points on Curve C are summarized in Figure 3.3. For each scenario, the sub-plots show the installed capacities of the generators, the percent penetration of the demand decision variables, and the proportion of electricity demand met by each generator (with efficiency counting as a generator). The error bars on the bar plots indicate the range of values found by the optimization algorithm that equally satisfied the problem formulation. In other words, different variations on a scenario all resulted in essentially the same overall costs and emissions.

Energy efficiency is maximized in all scenarios, which is consistent with the fact that efficiency measures have a negative lifecycle cost. Hydropower capacity is also maximized in every scenario, indicating that it is the least cost generation technology capable of reducing overall emissions. The capacities of PV and transmission for import/export are minimized in all scenarios, reflecting the fact that their relative costs are high compared to all of the other decision variables.

Generally, as the cost constraint is increased on the optimization, the model simultaneously employs two strategies to achieve the lowest GHG emissions possible. These strategies are: (1) increasing the capacity of renewables on the electric grid and (2) fuel switching in the transportation and heating sectors.

**Figure 3.3: Portfolios from Optimality Curve C**

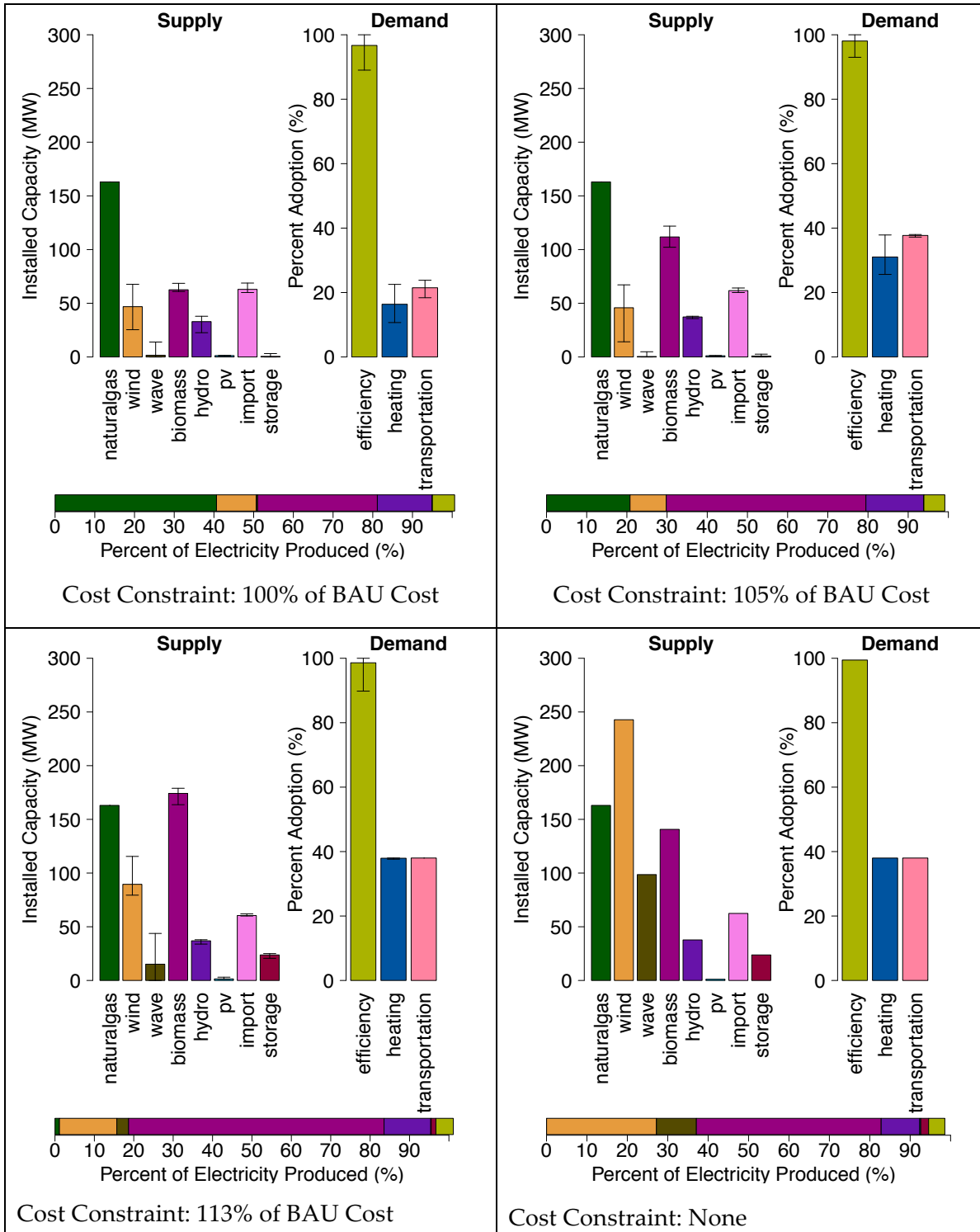

Installed capacities of generators (top left of each graph), penetration levels associated with efficiency and load building (top right), and the proportion of the electricity produced by each generator (efficiency is treated as a generator in this context). Colors in the grid mix bar match those in the upper plots and are in the same order from left to right. The error bars associated with the decision variables represent the range of values observed when the optimization algorithm had converged on a solution (i.e., the decrease in greenhouse gas emissions was the same within these error bars). BAU stands for business-as-usual.

Source: Schatz Energy Research Center.

To examine the uncertainty associated with the optimization results, the team conducted a Monte Carlo error analysis. For all points on the optimality curve shown in Figure 3.2 the model was run 500 times while the model input parameters were varied. Results indicate the model is robust, showing the uncertainty in GHG emissions and costs were only about  $\pm 6$  percent (based on  $\pm$  two standard deviations) for a  $\pm 10$  percent variation in model input parameters.

### 3.1.1.2 *Effect of Changes in Heat Pump and Electric Vehicle Penetrations*

The Monte Carlo error analysis only demonstrates the model sensitivity to input parameters. The constraints imposed on the decision variables can also have an impact on results. As it turns out, the limits on the penetration of electric vehicles and heat pumps in the transportation and heating sectors have a dramatic effect on the emissions reductions that can be realized. To examine this effect, the team conducted additional optimizations varying the limits on those two decision variables. The resulting optimality curves are plotted in Figure 3.4. The optimality curves identified as A through E correspond to electric vehicle and heat pump penetration limits of 0 percent through 76 percent, respectively. It is important to note that the authors do not consider curves D and E to be realistically achievable penetration levels for Humboldt County by the year 2030, and even curve C at a 38 percent penetration is likely overly optimistic. The 38 percent penetration level was based on PEV penetration projections for western Oregon (ETEC, 2010). The RePower Humboldt Strategic Plan assumed a maximum penetration level of 38 percent. Curves D and E were included in the analysis to examine the sensitivity of model results to that constraint.

There is a clear linear relationship between the emission reduction limit associated with each curve (represented by the horizontal line at the curve's asymptote) and the limit on electric vehicle and heat pump penetration. For every 5 percentage point increase in the penetration limits, the emission reduction limit decreases by about 3 percentage points.

This phenomenon led to one of the key lessons learned from this work. Increasing the penetration of renewable electricity is not sufficient nor necessarily the most cost-effective approach for reducing GHG emissions. To impact emissions from fossil fuels consumed in the heating and transportation sectors, it will be important to look for alternatives in those sectors as well. This study explored the potential to switch from fossil fuels in those sectors (predominantly gasoline and natural gas in Humboldt County) to electricity, while simultaneously increasing the penetration of carbon neutral renewable electricity.

### 3.1.1.3 *RePower Humboldt Strategic Plan Scenarios*

The project team used the REPOP model to develop a few representative scenarios to illustrate what is possible in Humboldt County regarding the development of local renewable energy resources and the resulting impacts on energy costs and GHG emissions. Three illustrative scenarios were developed for the year 2030. The three scenarios were named *business-as-usual* (BAU), *bold*, and *peak*. Figure 3.5 shows the installed energy generation capacity for each of these scenarios, as well as the penetration levels for energy efficiency, plug-in electric vehicles, and heat pumps. Figure 3.6 shows the energy provided by each of the generation sources. Note that efficiency is depicted as the equivalent of another generation source in Figure 3.6.

**Figure 3.4: Optimality Curves With Varying Limits on the Penetration of Electric Vehicles and Heat Pumps**

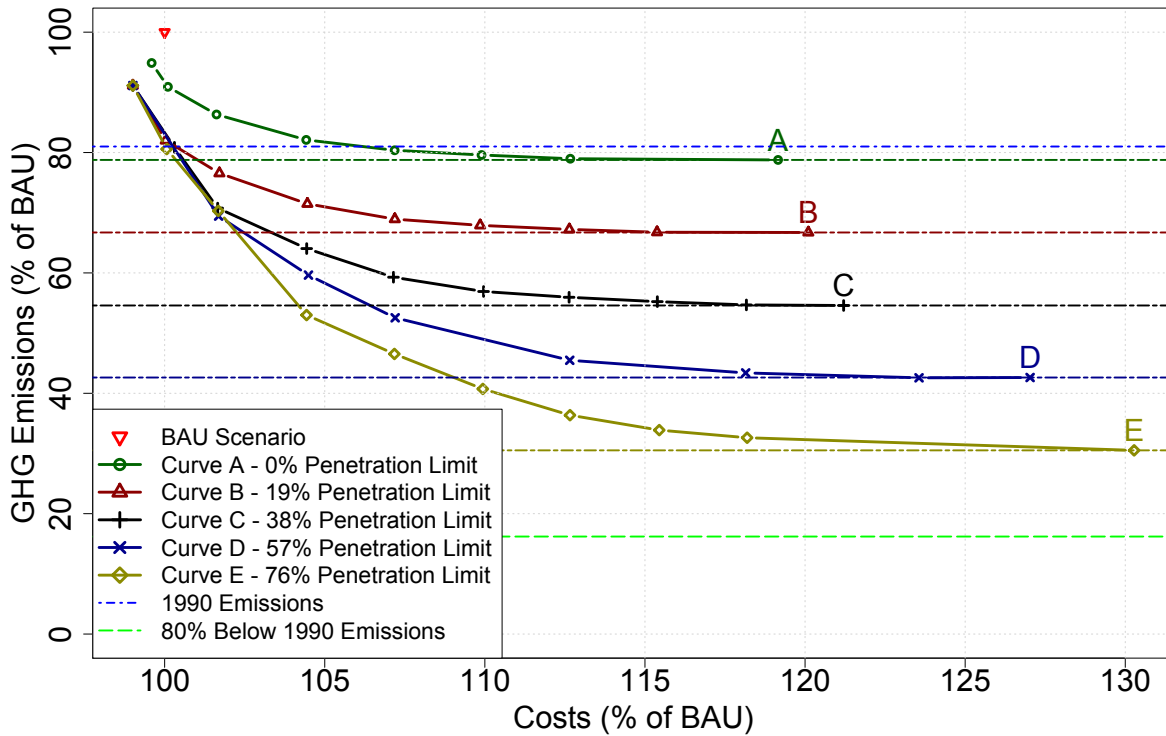

Each curve has a corresponding horizontal line indicating the emissions reduction limit at that penetration level. BAU stands for business-as-usual.

Source: Schatz Energy Research Center.

Figure 3.7 shows how the three scenarios compare in terms of cost, percent of renewable electricity, percent of total primary energy sourced locally in Humboldt County (including local natural gas), and GHG emission reductions. The **bold** scenario results in a 5 percent cost increase above *business-as-usual*, and the **peak** scenario results in a 15 percent higher cost. Note that these costs do not include the cost of associated transmission and distribution system infrastructure upgrades (see Section 3.1.2); however, these added costs are expected to be small in comparison to other costs when amortized over infrastructure lifetimes. Also note that these costs do not include added costs associated with a price on carbon emissions. Finally, note that even the peak scenario is not capable of keeping Humboldt County on track to meet California’s goal of an 80 percent decrease in GHG emissions from 1990 levels by 2050. That said, there are other sectors that also need to be addressed to successfully meet climate protection goals, so the peak scenario could be in line when only electricity, light duty vehicles in the transportation sector, and heating energy needs are considered. Finally, in retrospect the team considers the 38 percent limit on PEV and heat pump market penetrations by 2030 to be overly optimistic. A more reasonable upper estimate for PEVs is likely in the 10 percent to 20 percent range.

Section 3.3.2 compares job creation impacts associated with the business-as-usual, bold, and peak scenarios.

**Figure 3.5: Installed Capacities for BAU, Bold, and Peak Scenarios**

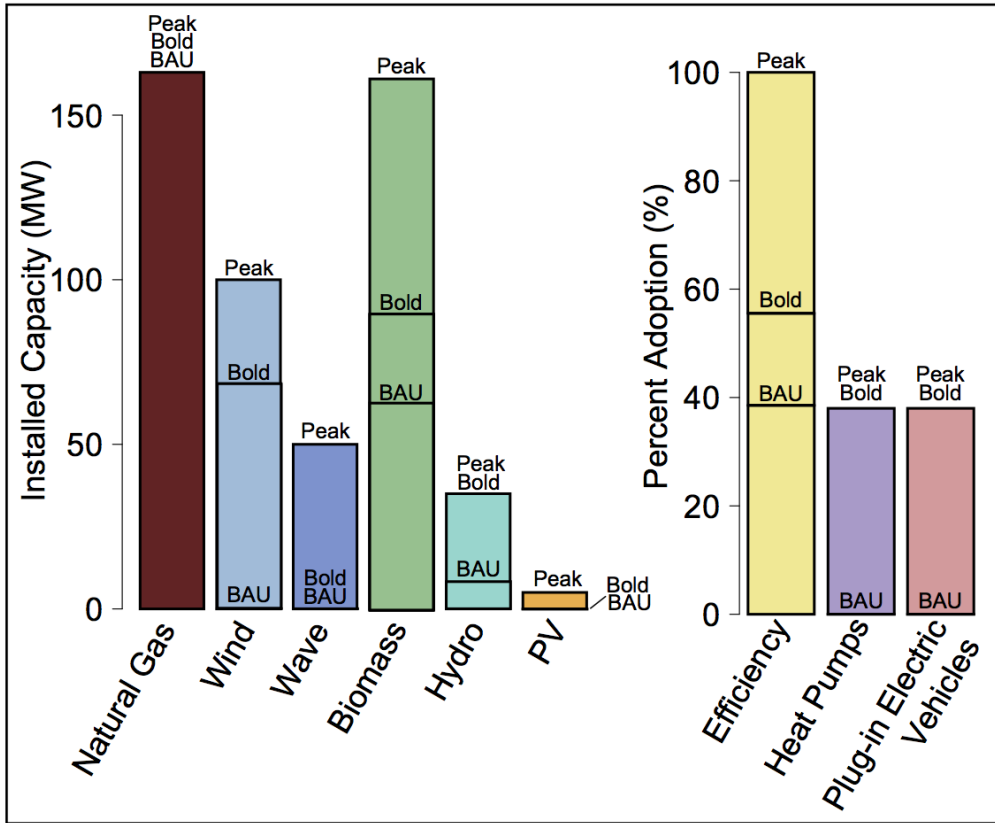

BAU stands for business-as-usual.

Source: Schatz Energy Research Center.

**Figure 3.6: Percent Electricity from each Generator for BAU, Bold, and Peak Scenarios**

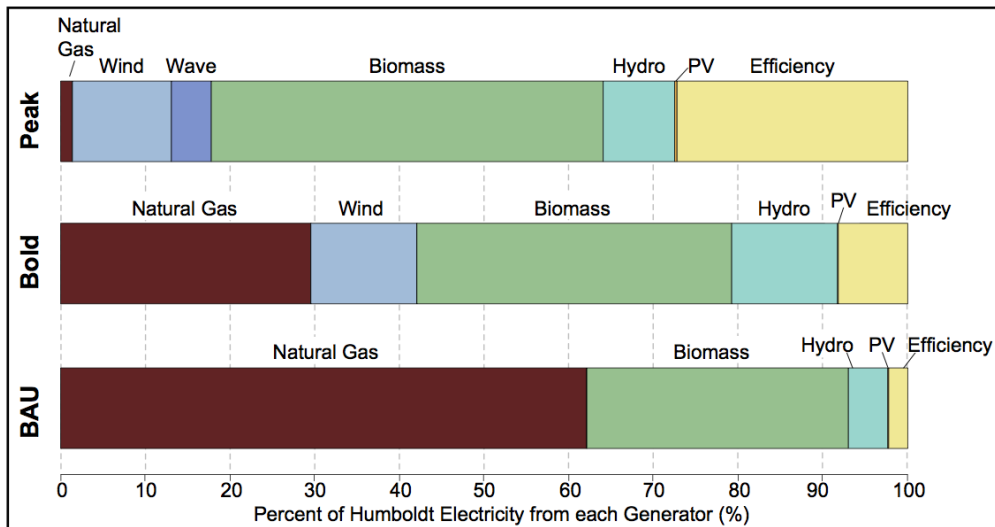

BAU stands for business-as-usual.

Source: Schatz Energy Research Center.

Figure 3.7: Comparison of Costs and Benefits for BAU, Bold, and Peak Scenarios

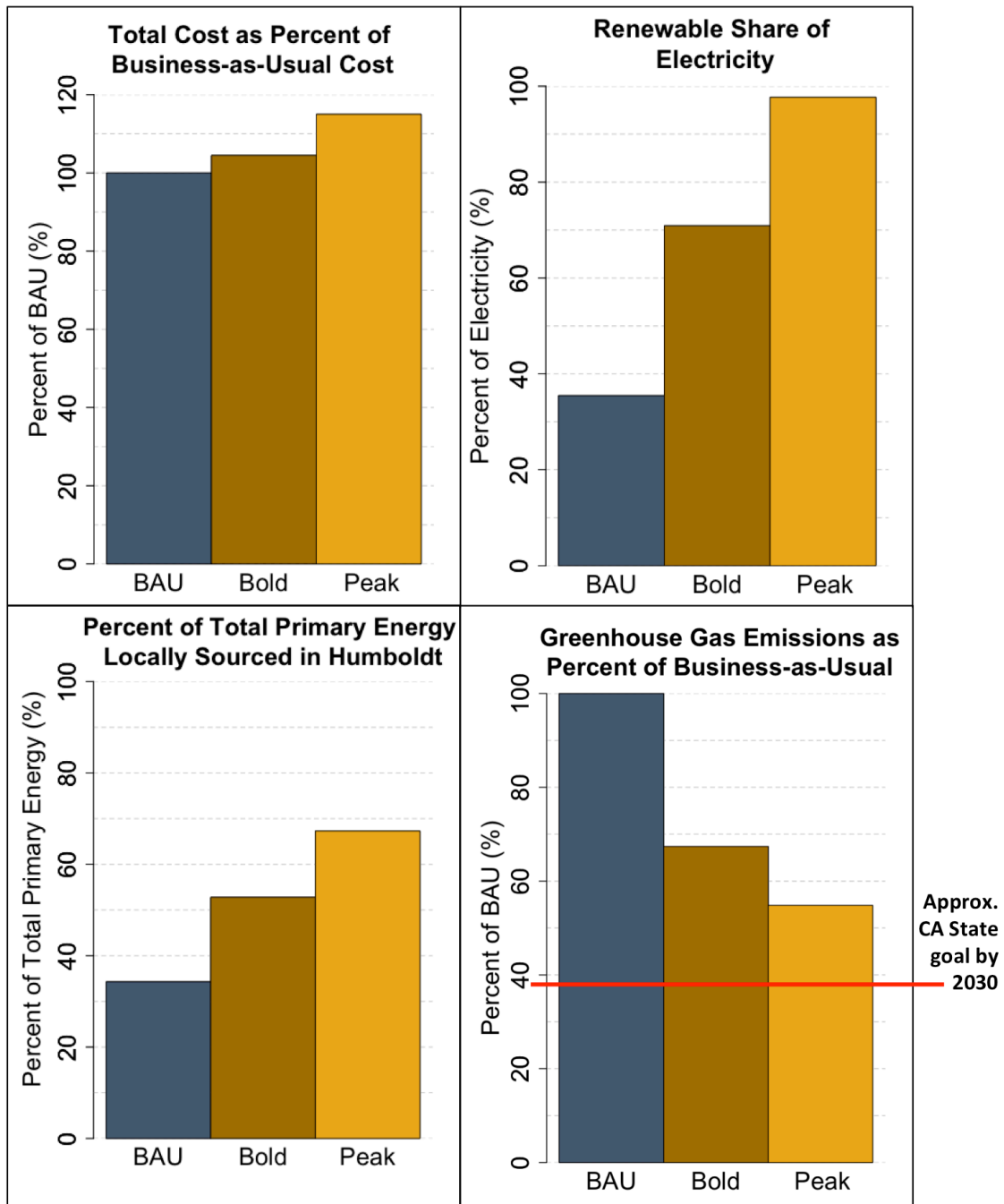

Source: Schatz Energy Research Center.

### 3.1.2 Interconnection Feasibility Study Results

The results of the interconnection study conducted by PG&E identified a large number of California Independent System Operator (CAISO) grid reliability criteria violations, including under normal operation (Category A), under single contingency conditions (Category B), and under select multiple contingency (Category C) conditions. The renewable energy build-out scenario studied by PG&E was most similar to the *peak* scenario identified above. The CAISO

violations indicate conditions on the Humboldt area electric grid that could result in power supply and/or power quality reliability problems. Given the number of violations identified, it was clear that a plan for mitigation must be investigated. PG&E developed three alternative plans for system upgrades that would correct the violations. In addition, PG&E provided non-binding, good-faith estimates of the cost of each alternative.

According to PG&E, the electricity transmission system in Humboldt County is composed primarily of 60 kV circuits designed to provide power to a geographically sparse population. The system is adequate for serving the local load, but would quickly become overloaded if mid-size to large generation capacity were added throughout the system. Adding 253 MW of renewable generation, as was analyzed, would require substantial upgrades to the transmission system to meet federal reliability standards. Table 3.1 summarizes the three alternative upgrade plans investigated by PG&E.

**Table 3.1: Transmission System Upgrade Alternatives Developed by PG&E to Mitigate Development of 253 MW of Renewable Generation**

Alternative	Description	Non-binding, Good-faith Cost Estimate
1 - Reconductoring, Voltage Support and Transformer Upgrades only	Leaves voltage of the system as is but increases the capacity of transmission circuits to allow increased power flow.	\$944 million
2 - Voltage Conversion, Reconductoring and Transformer Upgrades only	Convert some inter-county 115 kV transmission to 230 kV. Convert several intra-county circuits from 60 kV to 115 kV.	\$1002 million
3 - Build New 230 kV Line and Reconductor only	Convert circuits to 230 kV to substantially increase power flow from Rio Dell out of the County.	\$260 million

Source: PG&E, 2011a.

Alternative 1 involves increasing the capacity of existing transmission lines through reconductoring, transformer upgrades, and the addition of voltage support. This alternative is not recommended by PG&E as it is very costly and does not improve system reliability. In fact, according to PG&E, it could make the system operation more vulnerable to failures.

Alternative 2 focuses on increasing the voltage of selected transmission lines to increase the capacity of the system. The circuits identified for improvement include the export lines connecting Humboldt to Cottonwood and several other lines throughout the Humboldt Bay area and the southern end of the County. This alternative also requires extensive upgrades and is very costly.

Alternative 3 involves essentially one system upgrade, the conversion of the entire pathway between Rio Dell and Cottonwood to 230 kV. This alternative is designed to provide access to the greater California grid for the large capacity of wind power (125 MW) that was analyzed in the hypothetical development scenario. At \$260 million, this alternative is the least expensive; however, it is a custom solution and may not be suitable for a renewable portfolio that involves

less wind development and greater development of other resources in other locations. On the other hand, the substantial difference in cost between Alternative 3 and the other alternatives highlights the importance of a planning process capable of anticipating the location and extent of all (or most) of the new generation capacity. If generation projects are planned one at a time (that is, in isolation), then Alternative 1 may end up being the default pathway toward accommodating future projects. However, if project planning is coordinated across the region with a long-term perspective there could be opportunities for substantial savings.

One important note is that the approach PG&E followed to satisfy national reliability standards might be considered overly conservative and may substantially overstate the need for system upgrades. The analysis is based on a worst-case scenario that assumes *every* proposed generator (including the energy storage facility) in Humboldt County is producing electricity at full capacity. Essentially, all generators on the grid are assumed to be unmanaged. This approach ignores legitimate and potentially cheaper solutions to reliability concerns, such as using energy storage facilities as load (instead of generation) capacity, or curtailing generators during periods of excess power on the system. The REPOP model assumed that most generators, especially the 163 MW HBGS, could be curtailed when the total potential for power production exceeds the demand and ability to export.

NERC is the entity ultimately responsible for reliability standards on the grid. As stated in a recent report (NERC, 2009), NERC is well aware of these and other important issues relevant to the interconnection of variable power sources. They are currently working on solutions to the transmission planning process that will facilitate, rather than hinder, the rapid development of renewable power sources. Assuming the planning process is amended in the future, it is reasonable to assume that the upgrade cost estimates discussed above represent an upper limit to the cost of accommodating renewable energy development in Humboldt County.

Another aspect that should be considered in the context of significant upgrades to the Humboldt area transmission and distribution system is the possibility of creating a community scale microgrid in Humboldt that could operate independently from the statewide electric grid. While alternative 3 is clearly the cheapest option for overcoming the grid reliability problems associated with large-scale renewable energy development in Humboldt, it would not likely lead to a functioning microgrid. For this reason, an upgrade plan more like Alternatives 1 or 2 might be preferred if microgrid functionality is desired.

### 3.1.3 Hydrogen Transit Results

The hydrogen transit analysis found that at this time both the initial cost (for hydrogen fuel cell buses and hydrogen fueling infrastructure) and the annual operating costs are greater for a hydrogen transit system than for a diesel-based system. This presents a significant barrier to the introduction of hydrogen-powered transit. As a revenue negative system (mass transit systems do not generally bring in enough revenue to be self-supporting), Humboldt Transit Authority would need to find outside funding to pay for the additional costs. Transitioning to a hydrogen transit system would decrease carbon dioxide emissions, but at a high cost.

However, as fuel cell bus and hydrogen fueling technology mature, costs will likely come down and performance will improve. At the same time, the costs of diesel fuel and of associated air

emissions are likely to rise. At today's prices it was estimated that for a hydrogen transit system (buses and fueling infrastructure) to break even, a diesel price of \$9.68 per gallon would be necessary.

### 3.1.4 Forest-based Biofuels Results

Per mile lifecycle energy and GHG impacts of each fuel pathway considered are shown in Table 3.2. Lifecycle impacts for vehicles are often referred to as well-to-wheels impacts, though in the case of biomass the "well" is the forest. Relative to the baseline (conventional and reformulated gasoline for conventional vehicles), all three of the biofuel scenarios are more energy intensive, with the fermentation based ethanol pathway requiring the most energy (83 percent more than the baseline). Meanwhile, the PHEV and BEV pathways reduce energy use by 12 percent and 15 percent, respectively. All pathways significantly reduce fossil fuel use and GHG emissions relative to the baseline. BEVs have the largest impact, reducing fossil fuel use and GHGs by 95 percent and 92 percent, respectively, followed by the Fischer-Tropsch diesel (FTD) pathway, which results in reductions of 92 percent and 91 percent. The smallest impact, though still significant, is made via the PHEV pathway with a 47 percent reduction in fossil fuel use and 46 percent reduction in GHGs.

Clearly all of these fuel and vehicle combinations have the potential to drastically reduce transportation sector GHG emissions. The costs associated with the development of each fuel and vehicle pathway are important criteria by which to further assess these options. A comparative life-cycle benefit-cost analysis should be conducted for these biomass fuel pathways. In addition, technology maturity is also an important issue. Biomass fueled power plants are well proven and have been used for decades, and electric vehicles are on their way to becoming commonplace. However, producing refined biofuels from woody biomass is a technology that is still under development.

**Table 3.2: Well-to-Wheels Total Energy, Fossil Fuels, and GHG Emissions for Biomass Fuel Pathways**

Fuel Pathway	Total Energy (BTU/mi)	Relative to Baseline	Total Fossil Fuels (BTU/mi)	Relative to Baseline	GHGs (g/mi)	Relative to Baseline
Baseline: CG and RFG for CVs	5279	0%	4909	0%	405	0%
E85 (gasification) for FFVs	6557	24%	1794	(-64%)	149	(-63%)
E85 (fermentation) for FFVs	9684	83%	1050	(-79%)	111	(-73%)
FTD100 for CIDIVs	7367	40%	398	(-92%)	36	(-91%)
CG/RFG and electricity for SI PHEVs	4655	(-12%)	2594	(-47%)	219	(-46%)
Electricity for BEVs	4483	(-15%)	226	(-95%)	33	(-92%)

Percent change is relative to a baseline of conventional vehicles fueled with conventional and reformulated gasoline. CG = conventional gasoline, RFG = reformulated gasoline, CV = conventional spark-ignition vehicle, E85 = gasoline-ethanol blend containing 51% to 83% ethanol, FFV = flex-fuel vehicle, FTD100 = Fischer-Tropsch diesel, CIDIV = compression-ignition direct-injection vehicle, SI PHEV = spark-ignition plug-in hybrid electric vehicle, BEV = battery electric vehicle.

Source: Schatz Energy Research Center.

### 3.1.5 Key Findings

The resource and technology assessment resulted in the following key findings.

- Humboldt County can meet 75 percent or more of its electricity needs and a large fraction of its heating and transportation energy demand using local renewable energy resources. This can result in a substantial reduction in GHG emissions and can be achieved at a modest cost increase. The key challenges Humboldt County faces in meeting its energy goals are not related to the adequacy of local resources, but instead to the ability to develop these resources and the associated energy infrastructure needed to serve local demand with local renewable energy resources.
- There are many possible resource and technology options to choose from, and a mixed portfolio of options is likely more advantageous than any technology in isolation. Aggressive implementation of cost-effective energy efficiency opportunities should be a near-term pursuit. Biomass, wind, and small run-of-the-river hydroelectric energy sources should play a key supply-side role.
- The RESCO goal of meeting 75 percent or more of electric demand with local renewable resources may not be the best metric for measuring success. Instead, the project team recommends the focus be on cost-effective options to decrease *overall* GHG emissions across the whole energy sector.
- Fuel switching to plug-in hybrid and battery-only electric vehicles in the transportation sector and to electric heat pumps in the heating sector has the potential to play a major role in realizing the RESCO vision. Fuel switching opportunities are critical to cost-effectively achieving large reductions in energy related GHG emissions. Without fuel switching, deep reductions in GHG emissions are infeasible.
- An interconnection feasibility study conducted by PG&E indicates that substantial upgrades to the local transmission and distribution system will be required to accommodate large-scale development of local renewable energy sources. The most cost-effective plan for these upgrades would likely involve an area-wide planning approach that simultaneously considers multiple projects. If instead a project-by-project approach is taken, a less optimal piecemeal solution is likely to result. It is also important to note that non-standard approaches to maintaining grid stability, such as curtailing generation, should be considered in future analyses. Finally, transmission planning should also consider the possibility of creating a community-scale microgrid in Humboldt County that can operate independently of the statewide grid if necessary.
- Energy storage is not expected to play a significant role in the near- or even intermediate-term. This is due to the tremendous load following capabilities of the PG&E HBGS and the 70 MW of available transmission capacity.
- If there is no further development of clean energy alternatives in Humboldt County, model estimates for the *business-as-usual* scenario in 2030 show an electric supply dominated by power from the natural gas-fired HBGS (65 percent) and existing biomass power plants (30 percent). In the *business-as-usual* scenario the energy supply for the heating and transportation sectors will continue to be dominated by fossil fuels in the

form of natural gas (75 percent) and gasoline (100 percent). Transportation fuels will continue to dominate annual energy costs, and transportation fuels and natural gas usage will drive GHG emissions to 1500 kilotonnes of carbon dioxide equivalent per year (25 percent greater than 1990 levels). Clearly the business-as-usual scenario will not improve local energy sustainability, but instead will exacerbate the environmental problems associated with the current energy system while maintaining Humboldt County's exposure to fuel scarcity and price volatility.

## **3.2 Development, Financing and Ownership Options**

The project team identified, researched and evaluated financing and ownership models for the development of local renewable energy projects. The *Humboldt RESCO Task 3 Memo: Renewable Energy Development, Ownership and Financing Options* presents the findings from this work. This section briefly summarizes the findings. The discussion places special emphasis on identifying the most appropriate models for use in Humboldt County and how they can be used to help advance the RePower Humboldt vision.

### **3.2.1 Development and Ownership Models**

#### **3.2.1.1 Investor-Owned Utility**

The investor-owned utility model is predominant in Humboldt County. PG&E is the utility that serves the area, and they provide reliable electric power. Humboldt County is remote, rural, and rugged, so maintaining the transmission and distribution infrastructure is a substantial and costly effort<sup>1</sup>.

PG&E is involved in the local community. They have been a valued partner and supporter of local energy planning and research work, such as the RePower Humboldt study and a companion planning project for plug-in electric vehicle readiness. They have conducted model community engagement efforts via community advisory groups for both the Humboldt WaveConnect™ project and the Humboldt Bay Power Plant Nuclear Decommissioning Project. They are strong partners with the Redwood Coast Energy Authority via the Redwood Coast Energy Watch partnership.

It is safe to say that PG&E will continue to play an important role in Humboldt County's energy future, and there are numerous programs within the investor-owned utility model that can advance the RePower Humboldt Strategic Plan. These include: net metering, feed-in tariffs, renewable energy self-generation bill credit transfer program, direct access, and community choice aggregation<sup>2</sup>. In addition, independent power producers can continue to sell locally generated renewable electricity to PG&E. PG&E is even exploring a "green tariff" program that

---

<sup>1</sup> A 2004 cost evaluation report (E3 and RMI 2004) showed the cost of distribution in the North Coast region of California is approximately 25 percent higher than the PG&E system wide average.

<sup>2</sup> These programs are discussed in the *Regulatory and Policy Guide on Renewable Energy and Energy Efficiency for Humboldt County Local and Tribal Governments* (SERC, 2013a).

would allow customers to choose to purchase higher percentages of renewable electricity. All of these programs offer opportunity.

However, PG&E is a very large corporation and they typically don't move quickly. Anything they do involving ratepayer funds requires regulatory approval from the CPUC. This means that creative new program ideas, such as a local community power program that allows customers to share in the ownership of a local facility, are not likely to materialize quickly. For this reason the community should consider alternative possibilities for power generation, power plant ownership, and power purchase and sale. If there are available options that better serve the community's vision, goals, and needs, the community should consider them and be ready to act.

### ***3.2.1.2 Independent Power Producer***

Independent power producers have a long-established history in Humboldt County. Numerous biomass power plants and small hydroelectric power plants have been generating and selling local renewable electricity for decades. These projects serve to provide much-needed local electricity generation capacity, thereby helping to ensure reliable service in the area. In addition, they provide jobs and economic stimulus for the area. It is in the community's interest to continue to support these projects. Also, the independent power producer model is a well-established and functional model that can be used to develop additional renewable power projects in Humboldt County. Local leaders can look for ways to attract project developers who might want to develop new projects on the North Coast. In addition, it is possible for local independent power producers to sell power directly to the local community. This could be accomplished through a Community Choice Aggregation arrangement (discussed below), or potentially through a direct access agreement.

### ***3.2.1.3 Community Choice Aggregation***

Community Choice Aggregation (CCA) is a relatively new model that was introduced in California via legislation passed in 2002. It is an opportunity that allows greater control and decision-making power for local communities in the energy policy and planning arena. It allows communities, in aggregate, to choose where their electricity comes from. The CCA buys or generates wholesale electric power, and the power is provided to the CCA's retail customers via the incumbent utility's transmission and distribution system. The incumbent utility continues to provide all transmission, distribution, metering, billing, and operation and maintenance services. Establishment of a CCA can have impacts on the price a community pays for electricity, as well as the makeup of electricity they receive (for example, how much renewable content).

CCA is a model that is being actively considered in Humboldt County. Local leaders have been following the development and implementation of this model with the intention of learning from other community efforts and being ready to pursue the opportunity if and when the time is right. To date, Marin Clean Energy Authority is the only operating CCA in California; they serve Marin County and surrounding communities. In addition, there are many other communities in California that are at various stages of development, with Sonoma County and the City and County of San Francisco being two others that are far along in the process.

Some local municipalities in Humboldt County are considering the possibility of joining an already existing CCA. Conversations are on-going with the Marin and Sonoma CCA efforts. In addition, there has been discussion of creating an independent CCA that serves Humboldt County and perhaps other rural communities in northwest California. While this option would provide greater decision making power for the community, it would also require greater effort and greater cost, and therefore poses greater risk.

A CCA in Humboldt County could offer many opportunities for advancing the RePower Humboldt vision, and it would free up the local community to move as quickly and aggressively as they desire. The CCA could raise bond money and would be a revenue generator via sales of electricity. This would provide a means to raise the capital necessary to implement sustainable energy programs. The CCA could set its own rates, and in those rates could emphasize community priorities (for example, by cross-subsidizing renewable energy through higher prices for fossil energy, creating a de facto carbon tax). It could establish a robust energy efficiency program and could establish its own feed-in tariff and net metering programs. It could also finance, develop, own, and even operate its own electricity generation facilities. It could also buy power from existing independent power producers (local biomass and hydroelectric power plants) and could even buy power from PG&E. PG&E's local HBGS is a critical local asset that provides great load following capabilities. It is essential to allow for the large scale development of local intermittent renewable resources like wind and wave power, so it might make sense for a local CCA to purchase power from HBGS as one component of its power portfolio.

#### *3.2.1.4 Municipal Utility*

A municipal utility owns and operates the entire electricity system in the community, including the distribution system and sometimes even the transmission system. They are responsible for all utility operations, including power purchase and/or generation, power transmission and distribution, customer billing, system maintenance, planning, and many other critical services. To establish a municipal utility, a jurisdiction must acquire the distribution system (the electrical wires that crisscross and serve the entire community). This is typically an expensive and difficult process. In addition, as mentioned above, the cost of operating and maintaining the transmission and distribution system in a remote, rugged, rural area like Humboldt County is substantially higher than the average cost over PG&E's entire service territory. So, if Humboldt were to establish their own municipal utility those costs would become solely a local responsibility and would saddle the community with greater operating costs. For these reasons this option is not well suited for Humboldt County.

#### *3.2.1.5 Community Renewable Energy*

The types of community-based models that have been employed in the United States include utility sponsored models, where the utility develops, owns or operates a project that is open to voluntary ratepayer participation, as well as various special purpose entity models in which individual investors join in a business enterprise to develop a community renewable energy project. For example, a community renewable energy arrangement could allow a group of community members to combine their resources and participate in the ownership of local

renewable energy projects. This means that power would be generated at one or a number of locations, and then effectively transported through the distribution system to serve the participating customers. While the power may not physically be transported, the capability must be present since contractually this is what would take place.

In essence this is like a virtual net metering arrangement. With net metering a customer installs a renewable energy facility behind the revenue meter on its property. The customer then receives retail credit for any power that is sent back to the grid through the customer's revenue meter. In addition, the customer purchases normal grid power from its utility as needed. With a community renewable energy system, a centralized power generation system is located remotely, and a group of customers share in its ownership. Like with net metering they receive credit for the power generated and they purchase any additional needed power from their utility. However, one main difference between net metering and a community renewable energy system is that participating customers only get credit for the generation component of the power generated by the community system, whereas a net metered customer is credited at the full bundled retail rate<sup>3</sup>. This makes sense since the community power participants rely on the utility's distribution system to transport power from the community owned system to their homes and/or businesses where they use the power. Consequently, they pay for this service.

Currently this type of arrangement is not allowed in California. However, SB-43 (Wolk, 2013-2014, Shared renewable energy self-generation program) is pending legislation that would enable this sort of practice. Passing of this legislation could provide for interesting new opportunities for community members to support the development of local renewable energy projects. Another model for a community power program is the Sacramento Municipal Utility District's Solar Shares Program. This program allows customers to purchase power from a local, utility-owned solar farm. Customers pay a flat monthly fee to participate and then receive credit on their monthly bill based on how much power their solar share actually generates. Based on the public input received during the RePower Humboldt project, the authors expect there would be substantial support for a community renewable energy program in Humboldt County.

### 3.2.2 Financing Options

#### 3.2.2.1 *Large-scale Projects*

The project team identified numerous opportunities that could provide capital for developing local renewable energy projects. These include:

- **Government loan guarantees** - U.S. Department of Energy and U.S. Department of Agriculture.

---

<sup>3</sup> Retail electric rates include the cost of power generation, transmission, and distribution, as well as costs for reliability services, nuclear decommissioning, public purpose programs, and other costs associated with electric service. The full bundled rate includes all of these costs.

- **Public bond financing** - could be part of a Community Choice Aggregation arrangement or could support development of projects that directly serve municipal loads.
- **Private capital/equity or bank loans** - need a viable project that can meet funder's economic requirements, need to shop projects around and identify/attract investors.
- **Local sources of capital** - Headwaters Fund, possible development of a local investment fund, city of Arcata's high electricity use tax.
- **State and federal funds** - grant funds are limited, potential source of funding from carbon offset revenues generated via California's cap and trade program.

### 3.2.2.1 *Small-scale Projects*

Funding mechanisms are also needed to support small- to medium-scale distributed energy projects located at customer facilities (homes and businesses). Opportunities in this arena include:

- **Property Assessed Clean Energy (PACE)** – The CaliforniaFIRST program is bringing PACE opportunities to California, with many communities developing programs. Humboldt County is currently working to develop a local PACE program.
- **On-bill financing** – PG&E currently offers on-bill financing to business customers and government agencies for select energy projects.
- **Power purchase agreements, leasing, and performance contracting** – Private financing opportunities exist through various third party arrangements; projects must meet investment criteria.
- **All-in-one program** – The Redwood Coast Energy Authority is looking to expand its current program offerings. They are looking to create a robust, all-in-one program that supports participants from start to finish in their sustainable energy projects. Services could include: project assessment; financing; project management; interconnection, permitting and incentive paperwork; bulk purchasing; standardized pricing; and pre-approved contractors.

## 3.3 **Economic Analysis**

The Humboldt RESCO economic analysis assessed costs and benefits associated with renewable energy development in Humboldt County. This section summarizes the findings of the economic analysis. For a more detailed description of the analysis see *Humboldt County as a Renewable Energy Secure Community: Economic Analysis Report* (Hackett et al. 2012).

### 3.3.1 **Renewable Energy Cost Results**

The team examined three main indicators of cost for each energy generation technology: instant capital cost, the marginal cost of energy supply, and the levelized cost of energy (LCOE). The instant capital cost of a project is a standard economic method of estimating the up-front cost of

a project. Instant capital cost is based on the assumption that the project is completed overnight, and therefore no interest-based financial carrying costs on construction loans are incurred in the construction period. The team obtained instant capital cost estimates from a number of sources and averaged the estimates for each technology type. Figure 3.8 shows the range (in blue) of cost estimates as well as averages (in red) for each technology. The values used in the Humboldt RESCO analysis are marked in black and displayed above each bar. In general, costs similar to the literature averages were used, however, where information was available regarding likely generation costs specific to Humboldt County the authors made adjustments as warranted. Natural gas has a considerably lower upfront cost on a per-kilowatt basis than any of the renewable technologies.<sup>4</sup> Wind, at one and a half times the cost of natural gas, has the lowest instant capital cost of the renewables, while solar PV is the most expensive technology.

**Figure 3.8: Instant Capital Cost Estimates**

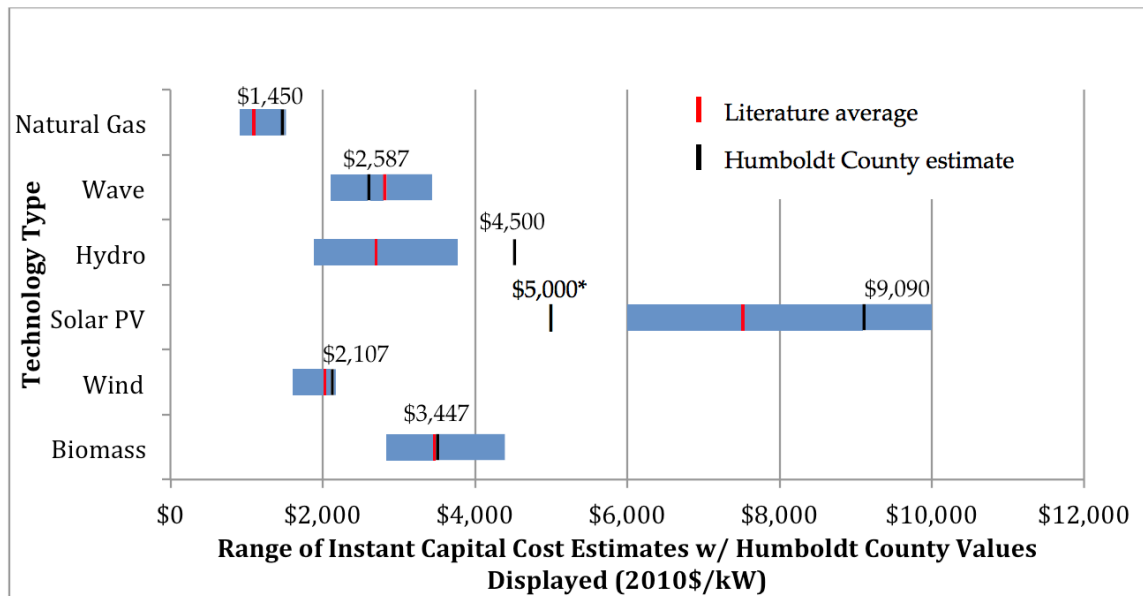

\*Installed solar PV prices for distributed rooftop systems in Humboldt County in early 2010 when the economic analysis was conducted were on the order of \$8 to \$10 per watt. Since that time they have dropped dramatically. Current prices are on the order of \$5 per watt.

Source: Schatz Energy Research Center.<sup>5</sup>

The authors calculated marginal cost of energy supply for each technology based on the total levelized variable costs (fuel plus variable operations and maintenance) used in the National Renewable Energy Laboratory (NREL) Jobs and Economic Development Impact (JEDI) models

<sup>4</sup> Literature ranges for natural gas instant capital cost presented here and levelized cost of energy estimates presented below are reflective of conventional combined cycle gas turbines, not the internal combustion engines at the HBGS. These were the most representative cost data available to the authors.

<sup>5</sup> The authors obtained instant capital cost estimates from: E3, 2008; EERE, 2009; EIA, 2009; EPRI, 2009; KEMA, 2009; Klein, et al., 2007; Klein, 2010; Lazard, 2008; McKinsey, 2007; O'Donnell et al., 2009; PIER, 2007; and Wiser, et al., 2009.

for natural gas, wind, and solar PV, and in the Schatz Energy Research Center (SERC) models for small hydro, wave, and biomass.<sup>6,7,8</sup> Figure 3.9 is illustrative of one possible scenario for total installed capacity of each technology and shows that solar PV, wind, small hydro, and wave energy have the lowest marginal cost of supply. This is expected because these technologies are not subject to high and escalating fuel prices. Marginal cost of energy supply estimates for biomass and the PG&E internal combustion engines at HBCS are considerably higher, with natural gas reaching nearly \$60/megawatt-hour (MWh). Figure 3.9 illustrates the fact that after the capital investments in infrastructure are made, renewable technologies are considerably cheaper to operate and maintain.

**Figure 3.9: Humboldt County Marginal Cost of Supply**

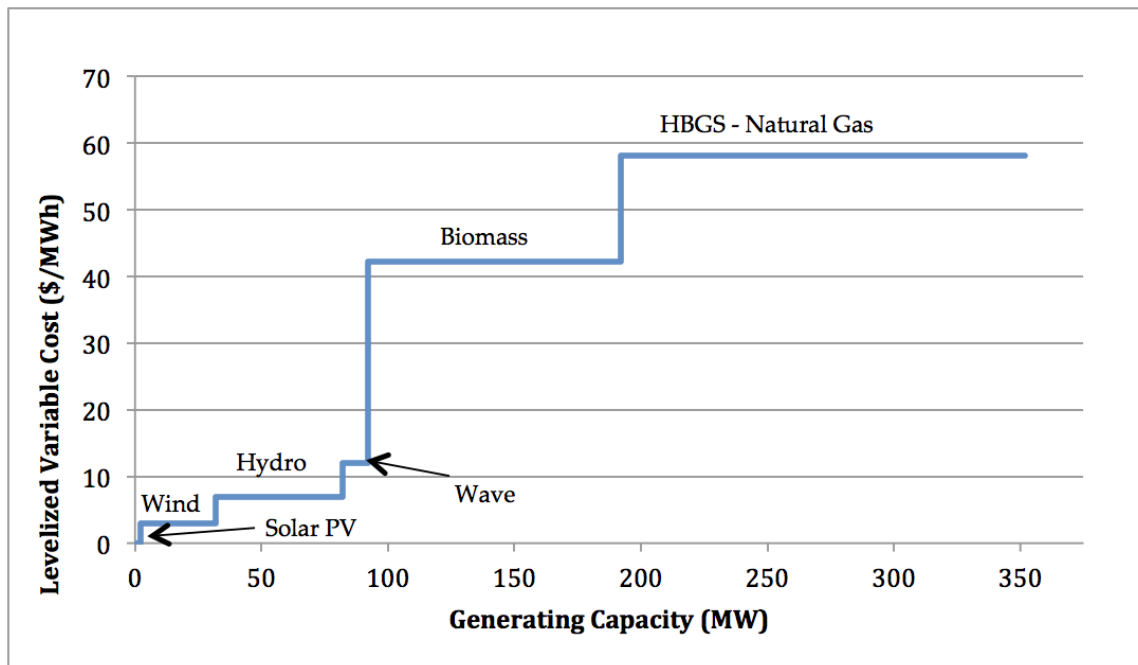

Source: Schatz Energy Research Center.

Levelized cost of energy (LCOE) is a metric that estimates the cost per unit of energy generated by a given technology over its useful life. LCOE is the most inclusive of the cost terms as it includes capital costs, as well as fixed and variable O&M costs. Levelized costs of energy values in this study, however, do not include environmental, system diversity, or risk factors that may influence cost. The authors obtained estimates for LCOE borne by the developer from a number

<sup>6</sup> Given the uncertainty of future biomass and natural gas fuel prices, the authors calculated levelized variable cost under the assumption that fuel prices increase at a rate equal to general inflation.

<sup>7</sup> The NREL JEDI model for wind does not include a variable O&M component. Variable O&M for wind included here is based on *Comparative Costs of California Central Station Electricity Generation* (Klein, 2010).

<sup>8</sup> The term marginal cost of energy supply is used to reflect the incremental cost of supplying an additional megawatt-hour of energy. Note that intermittent renewable energy resources such as wind, wave, and solar PV are not dispatchable.

of sources for each renewable technology type and for energy efficiency.<sup>9,10</sup> Literature ranges, average values, and Humboldt County LCOE estimates are displayed in Figure 3.10.

Comparing Humboldt County estimates across technologies, energy efficiency immediately stands out as the lowest cost energy option. LCOE estimates for natural gas, wind, hydro, and biomass are all within the \$90-\$116/MWh range, which indicates that a cost competitive portfolio of energy options exists in Humboldt County. Wave energy is not a mature technology, and cost estimates are therefore preliminary and highly uncertain. Solar PV is estimated to be the most expensive energy option in Humboldt County.

**Figure 3.10: Levelized Cost of Energy Estimates**

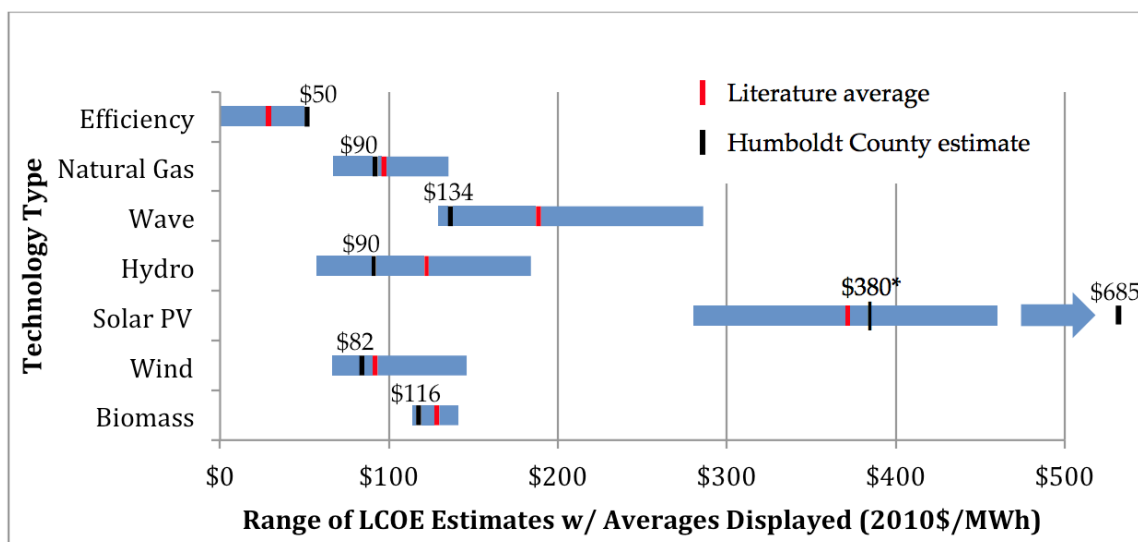

\*Installed solar PV prices for distributed rooftop systems in Humboldt County in early 2010 when the economic analysis was conducted were on the order of \$8 to \$10 per watt. Since that time they have dropped dramatically. Current prices are on the order of \$5 per watt and below. This drop in prices has cut the LCOE for solar PV almost in half.

Source: Schatz Energy Research Center.

### 3.3.2 Economic Impact Results

As discussed in Section 2.4.2, the team used NREL JEDI models and similarly designed SERC economic impact models to estimate the job creation, economic output, and earnings impacts associated with various renewable energy development opportunities. The project team developed economic impact factor estimates on a per-megawatt basis for each generation technology. Individual impact factors were generated for earnings (2010\$/MW), economic output (2010\$/MW), and job creation (jobs/MW) during the construction and operating periods.

<sup>9</sup> The authors obtained levelized cost of energy estimates from: ACEEE, 2009; Black & Veatch, 2010; E3, 2008; EIA, 2009; EPRI, 2009; KEMA, 2009; Klein et al., 2007; Klein, 2010; Lazard, 2008; PIER, 2007; and Price, et al., 2010.

<sup>10</sup> Note that saved energy is not a physical “source” of energy but rather a way of displacing additional generation. As investments could be made either to install additional generation capacity to meet growing demand or to reduce demand through efficiency and thus avoid installing additional capacity, these two energy “sources” are fully fungible.

The team calculated these factors using multiple illustrative runs of the JEDI and SERC economic impact assessment models for a range of realistic generation capacities for each technology.

Figure 3.11 and Figure 3.12 show graphical representations of job creation impact. To normalize for the intermittency of renewables, the authors also derated job impacts per MW by capacity factor (jobs/MW<sub>a</sub>).<sup>11</sup> The derated impacts provide a fairer comparison across generation technologies with widely varied capacity factors. For instance, because solar PV operates at a lower capacity factor than natural gas, more installed capacity would have to be constructed, operated, and maintained to satisfy 1 MW of additional demand with solar. Additionally, the analysis divides total job creation impacts per MW for each technology into direct, indirect, and induced impacts (see Hackett et al. 2012 for a description of impact types).

**Figure 3.11: Construction Phase Job Creation per MW(a)**

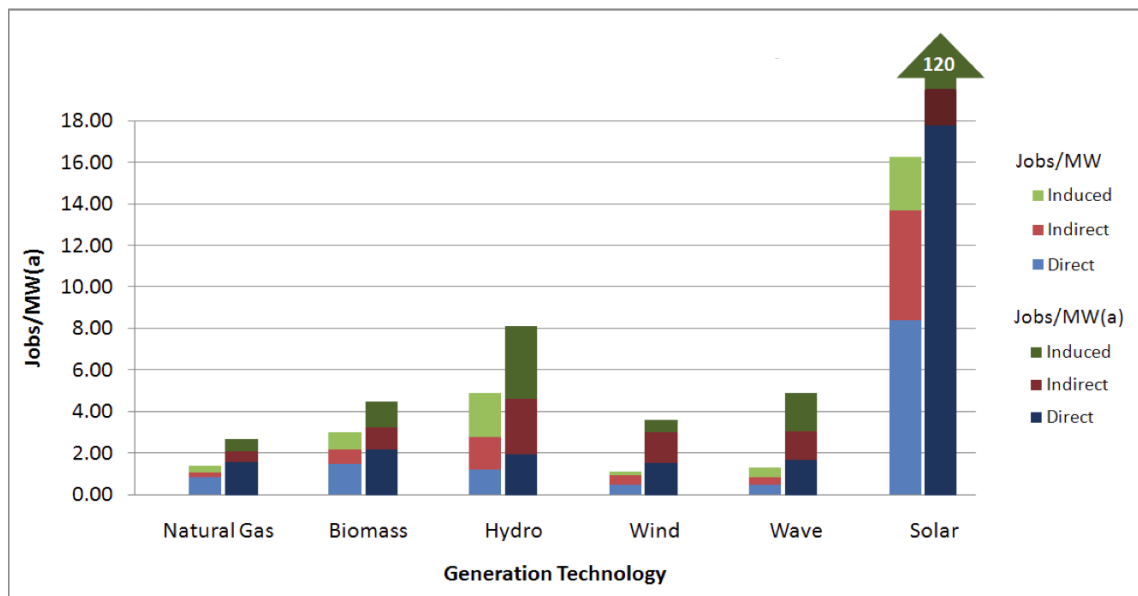

Source: Schatz Energy Research Center.

<sup>11</sup> Figure 3.11 and Figure 3.12 assume capacity factors of 51 percent for natural gas generation, 67 percent for biomass, 26 percent for wave power, 60 percent for hydroelectric, 30 percent for wind, and 13.5 percent for solar PV.

**Figure 3.12: Operations Phase Job Creation per MW(a)**

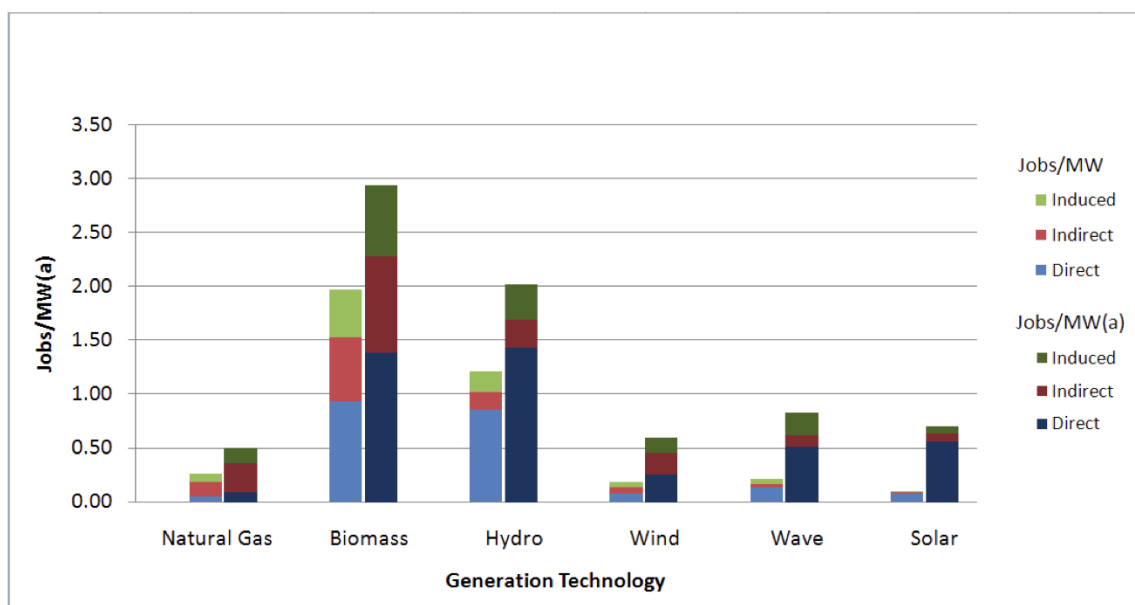

Source: Schatz Energy Research Center.

Figure 3.11 indicates that natural gas generation creates the fewest jobs per MWa during the construction phase while solar PV creates the most. The large number of jobs resulting from PV installation is due to the fact that 1 MW of installed capacity is composed of many small scale residential and commercial installations, which is labor and capital intensive. Additionally, the Humboldt County solar resource is relatively poor, so when derated by capacity factor (13.5 percent), job creation per megawatt of anticipated solar PV power production is quite high. More generally, all of the renewable technologies have higher construction phase job creation impacts than natural gas on a per MWa basis.

Solar PV, wind, and wave energy create the fewest long term jobs per MW during the operating phase, primarily because they do not require fuel and require relatively low maintenance. When derated by capacity factor, however, all of the renewable technologies have a higher job creation impact (per MWa) than natural gas-fired generation. Biomass power production creates the most jobs during the operations phase. Approximately half of these job creation impacts are plant workers (direct jobs) and about a third are in the local fuel supply chain (indirect jobs).<sup>12</sup> Because of the prolific timber industry in and around Humboldt County, biomass benefits from a higher proportion of indirect impacts than any of the other

<sup>12</sup> Personal communications with local biomass plant operators suggested that they employ approximately 1 worker per MW of installed capacity.

technologies. Natural gas generation also benefits from some local fuel supply chain impacts, though not nearly as substantially as biomass does.<sup>13</sup>

None of the economic impact models employed in this study calculate net impacts. However, by using a suite of models for the entire portfolio of energy options, net job creation can easily be inferred. Because all renewable technologies have higher job creation impacts per MWh than natural gas generation during the construction and operations phases, any combination of renewable technologies used to offset natural gas will have positive net impacts.

Study results indicate that investment in energy efficiency is likely to have a small but positive impact on the Humboldt County economy. Over the 20-year forecasting period, total mean job creation is anticipated at 15.6 full time equivalent (FTE) jobs per year. This amounts to approximately 0.37 full time equivalent jobs/GWh, which is consistent with the meta-reviews by Kammen et al.(2006) and Wei et al. (2010).<sup>14</sup> A common finding among energy efficiency studies is that the majority of the impacts resulting from efficiency programs stem from additional household consumer spending generated by consumer energy bill savings (SWEEP, 2002; Roland-Horst, 2008). As consumers save money on their energy bills, a portion of that savings is spent on goods and services within the community, resulting in more jobs, higher earnings, and more economic output. The model results indicate that energy bill savings create nearly twice the number of jobs as installation, driven by mean net present value savings of \$3.7 million annually.

Figure 3.13 shows the number of construction and operations phase jobs, by generation source, for the *business-as-usual (BAU)* and *bold* scenarios. Note that construction jobs are shown for facilities that have already been built (for example, the PG&E HBGS and the local biomass and hydroelectric plants). Therefore to assess the impact of the *bold* scenario you must examine the net difference between the two scenarios.

---

<sup>13</sup> The authors assumed 13 percent of the natural gas used at the HBGS comes from local sources. The authors calculated this figure based on 2008 Humboldt County gas field production as a fraction of 2008 countywide natural gas use from the Energy Commission. Interviews with local biomass plant managers indicated that approximately 75 percent of their fuel is sourced locally.

<sup>14</sup> Total present value job creation from electrical energy efficiency programs is estimated at 303 jobs over the 20-year forecasting period, with an associated energy savings of 830 GWh.

**Figure 3.13: Operations and Construction Phase Job Creation for BAU and Bold Scenarios**

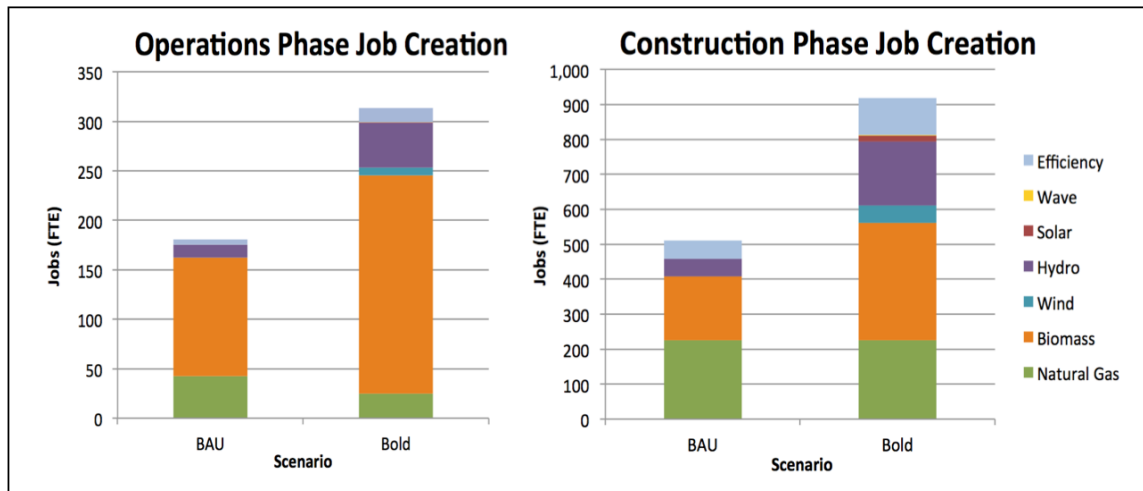

Source: Schatz Energy Research Center.

Finally, Figure 3.14 provides an estimate of the net total annual jobs created in the *bold* and *peak* scenarios. In this case all jobs have been annualized. In other words, construction jobs have been averaged out over the 17 years between 2013 and 2030. If actual construction of projects is staggered throughout the period this is a reasonable approximation of expected job impacts.

**Figure 3.14: Total Annual Job Creation for BAU, Bold and Peak Scenarios**

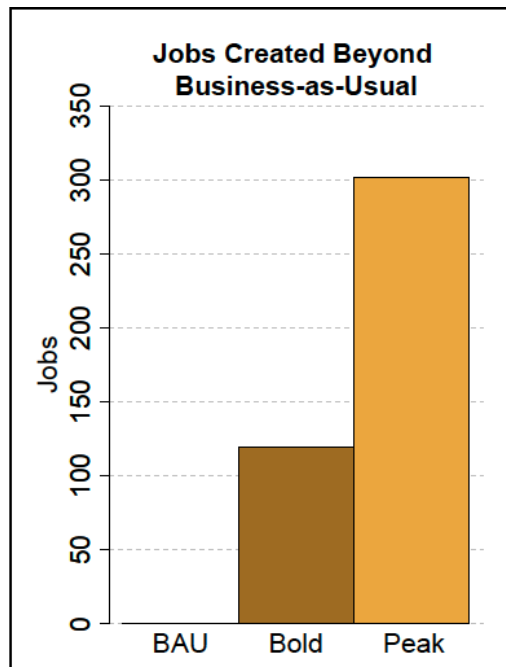

Source: Schatz Energy Research Center.

## 3.4 Regulatory and Political Issues

The RePower Humboldt project team identified and assessed a list of regulatory and political challenges that may need to be overcome to achieve the RePower Humboldt vision. Project activities included the development of a regulatory and policy guide, as well as a regulatory and political issues memo.

### 3.4.1 Regulatory and Policy Guide

The *Regulatory and Policy Guide on Renewable Energy and Energy Efficiency for Humboldt County Local and Tribal Governments* is action-oriented and provides local policy makers with resources and tools they can use to increase energy sustainability in their communities. A list of action areas covered in the guide is shown below.

- Building Organizational Capacity
- Leading by Example with Municipal Energy Projects
  - Energy efficiency and renewable energy
  - Green fleets / alternative fuel vehicles
  - Financial benefits of generating your own electricity
  - Funding opportunities
  - Energy purchase and price options and information on energy use
- Incentives and Programs to Reduce Implementation Barriers
  - Renewable energy and energy efficiency incentives
  - Financing programs, bulk purchasing, and other financial interventions
- Planning, Permitting, and Regulation
  - Planning and regulation
  - Permitting
  - Providing a public forum
  - The climate change energy nexus
- Community Power
  - Planning and implementation of energy efficiency programs
  - Generation, distribution, and/or sale of electrical power
- Education and Outreach

### 3.4.1 Regulatory and Political Issues Memo

The RePower Humboldt project team developed the *Task 5 Memo: Regulatory and Political Issues – Challenges to Implementing the RePower Humboldt Strategic Plan*. This memo outlined a key set of challenges and suggested strategies for overcoming them. A summary of the memo is presented below.

- Onshore wind power: There are siting challenges; the key resource area is located in an Audubon Society designated Important Bird Area (IBA).  
*Approach:* Conduct a constraints and opportunities analysis that identifies preferred areas for wind energy development, as well as a program level environmental review.
- Wave and offshore wind power: These are immature technologies with regulatory and permitting hurdles.  
*Approach:* Serve as a venue for future offshore renewable energy research and demonstration. Help facilitate permitting process.
- Forest biomass: Need coordination with forest restoration and management. Need to share benefits and costs. Need to determine sustainability and secure public acceptance.  
*Approach:* Biomass energy industry and forest restoration/management community need to work together. Figure out ways to share costs and benefits. Develop guidelines regarding acceptable practices that will ensure sustained forest health and secure public support.
- Forest biomass: There is uncertainty regarding renewable status, carbon neutrality, and ash disposal issues.  
*Approach:* Carefully monitor these issues. Conduct a study for the North Coast region that assesses biomass resource availability, energy conversion pathways, and associated lifecycle impacts with regard to carbon emissions.
- Distributed generation (DG): There are potential permitting hurdles, interconnection challenges, and inadequate pricing for power sales.  
*Approach:* Work with municipal staff to educate them about DG technologies and provide them with lessons learned in other jurisdictions where similar systems have been installed. Modify zoning regulations to specifically allow DG technologies as a permitted use where appropriate.
- Small hydroelectric: There are major regulatory/permitting hurdles and transmission and distribution (T&D) access issues. Need to identify prime sites where environmental and T&D issues are minimal.  
*Approach:* Conduct an assessment of the small hydro resources in the region. Identify streams with adequate flow and head. Identify streams with natural barriers to anadromous fish passage. Identify sites with good access to transmission and distribution infrastructure.
- Renewables pricing: There are issues with existing PURPA contracts (biomass, small hydro) and the low cost of conventional natural gas generation resources.  
*Approach:* Encourage successful negotiations with PG&E and the CPUC to allow existing plants to continue operating. Identify alternative buyers who might pay a higher price.
- Transmission and distribution system upgrades: Upgrade costs are high. There is need for long-term planning. How can the local community participate in the T&D upgrade discussion? How will upgrades be funded?  
*Approach:* Consider long-term perspective. Involve local stakeholders. Include assessment of how upgrades can be funded.
- Public perceptions include distrust in large corporations and preference for community-based projects. Challenges include difficulty securing capital and a need for effective local ownership models.

***Approach:** Facilitate successful working relationships between interested outside developers and local community stakeholders. Pursue Community Choice Aggregation opportunity. Advocate for passage of SB 43 to enable community renewable energy.*

- There is a lack of consumer choice to buy renewable power, especially locally generated power.

***Approach:** Use net metering and direct access. Advocate for PG&E's "green tariff." Pursue CCA. Advocate for passage of SB 43.*

- There are community concerns regarding local impacts of renewable energy projects. There is a need for transparent processes that involve the local community in project planning and development.

***Approach:** Need an open and transparent planning and development process that involves the local community in a meaningful way. PG&E WaveConnect stakeholder process can serve as a successful model.*

- All options have impacts, including the "do nothing" option. How does this get accounted for in the review process?

***Approach:** When proposed renewable energy projects are being assessed, the cumulative impacts of the no project alternative, including greenhouse gas emissions and other negative impacts associated with conventional fossil fuel based energy systems, should be considered.*

- There are planning, permitting, and regulatory hurdles for renewable energy project development. Process needs to be streamlined.

***Approach:** Engage in proactive planning efforts to streamline the review process. Conduct a constraints and opportunities analysis that identifies preferred areas for development (and areas that are not compatible). Conduct a program level environmental review. Assess key issues that need to be addressed. Create guidelines and standards for development. Create zoning designations to protect prime areas for future development.*

- To meet climate change goals, the transportation and heating sectors must be addressed. This will require ambitious market penetration of PEVs and will be challenging.

***Approach:** Conduct local PEV readiness plan and heat pump study. Promote and plan for PEV and heat pump adoption.*

- There is a need for coordination between regional planning efforts, including energy planning, climate action planning, and EV infrastructure.

***Approach:** Coordinate between efforts and across geographic regions and government agencies. Ensure cost-effective use of resources. Leverage resources across programs and regions. Eliminate duplicative efforts or those at cross-purposes.*

- In the RePower Humboldt *peak* scenario the PG&E HBGS will run at a very low capacity factor, but it will provide critical load following, reserve capacity, and reliability benefits. Are there any issues with the plant becoming a "stranded asset?"

***Approach:** Make sure it is clear what critical value the HBGS provides to the region.*

- How does a small community fund the programs and infrastructure needed to develop substantial local renewable energy resources?

***Approach:** Attract outside entities to develop, own, and operate facilities. Develop opportunities for local community ownership and participation. Identify committed and well-informed local project champions. Prepare for project development by conducting resource assessments, feasibility studies, permitting work, zoning work, interconnection studies, power purchase negotiations, and public engagement, education, and outreach activities.*

### **3.5 Stakeholder Analysis**

The RePower Humboldt project team conducted a stakeholder analysis to assess community goals, preferences, and concerns related to renewable energy development in Humboldt County. This work is documented in the *Humboldt RESCO Task 6 Memo: Stakeholder Analysis*. Lessons learned from the stakeholder analysis are summarized below.

- Key criteria to be considered for future energy projects include: environmental impacts, financial viability/affordability, local acceptance/participation/control, and economic impacts (jobs, economic stimulus).
- With regard to local participation and control, people would like to see projects that are developed and owned locally. People would also like the ability to purchase locally generated electricity. People are less enthusiastic about power that will be generated locally and sold to other electricity consumers located outside of the region.
- There is some distrust of large multinational corporations. Projects developed by large, out-of-the area corporations are less likely to find favor in the community. However, access to capital may require the participation of outside interests.
- While people are concerned about global environmental issues, they become much more personally involved when a project is located in their neighborhood and will impact their own local environmental quality.
- It is important to engage people early in the project development process and give them a chance to voice their concerns.
- People want to feel listened to. Their input should be solicited and responded to in concrete ways so they can see that their input is making a difference.
- People want to see real, tangible benefits for their communities associated with proposed projects, especially if they perceive they or their community is giving something up in the process.
- The community can benefit from an education and outreach campaign that provides information about how much energy is consumed, where it comes from, and what the associated impacts are. Information about energy alternatives and the trade-offs associated with these alternatives should also be made available.
- People want to be engaged in a two-way conversation. They do not want to be talked at or talked down to.
- People often voice a preference for small-scale, distributed energy systems located close to where the power is needed. While these systems can play an important role, there

will also need to be larger scale projects to provide a significant portion of energy using local sources. This is an education and outreach topic that needs to be addressed.

- Offshore wind and wave energy: The public process surrounding the recently proposed PG&E WaveConnect project showed the local fishing community is concerned about the impacts that offshore energy (wave power, wind power) might have on their industry. Possible environmental impacts were also raised during this process. However, there was also a lot of public support for the proposed PG&E WaveConnect project.
- Onshore wind energy: While there were those in the community that voiced support for the project, there was also a significant amount of opposition toward the proposed Shell WindEnergy Bear River Ridge wind power project. Key concerns included potential impacts, such as: impacts to local tourism, impacts to roads, construction impacts and disruption to town activities, impacts to the town water supply, impacts to birds and bats, and visual impacts. This project has since been discontinued, but if there are future attempts to pursue a wind project on Bear River Ridge they will likely encounter some of the same opposition.
- Biomass energy: Concerns have been voiced about the expansion of biomass power in Humboldt County. People are concerned about potential negative impacts to the local forest ecosystem and creating a situation where trees are being cut to feed a power plant (as opposed to capturing an otherwise unused waste stream). Concerns have also been voiced about the sustainability and carbon neutrality of biomass energy.
- Small hydro energy: It is anticipated that there will also be concerns about the development of small-scale, run-of-the-river hydroelectric projects and the impacts these projects could have on aquatic ecosystems. Although it is true that any approved project would need to meet stringent environmental criteria and overcome significant permitting and regulatory hurdles, there still may be concern about potential impacts.

### 3.6 Strategic Plan

The culminating document for the RePower Humboldt project is the RePower Humboldt Strategic Plan. It sets a context for Humboldt County's energy future, describes the strategic planning process, and presents the vision statement and community values developed by the RePower Humboldt stakeholder group. The plan presents results of the resource and technology assessment and economic analysis, and three representative scenarios, *business-as-usual*, *bold* and *peak*, illustrate what is possible. Also provided is a set of long-term strategies and near-term next steps, as well as a preliminary evaluation plan. The plan summarizes near-term next steps in a tabular format that identifies responsible parties, a proposed implementation schedule, and potential resources to support the effort.

The authors produced the RePower Humboldt Strategic Plan in a professional, user-friendly format intended to be accessible to the general population. Graphic images of the cover page and table of contents are shown in Figure 3.15, and key findings presented in the RePower Humboldt Strategic Plan are shown in Figure 3.16.

**Figure 3.15: RePower Humboldt Strategic Plan Cover and Table of Contents**

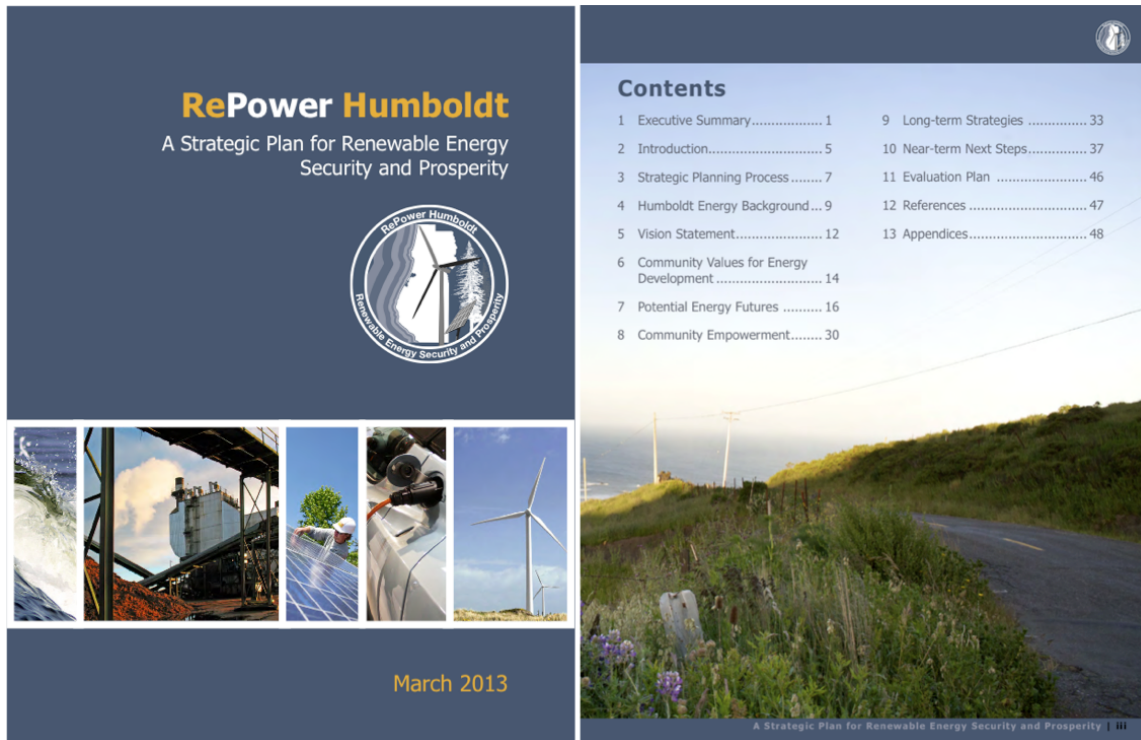

Source: Schatz Energy Research Center.

**Figure 3.16: RePower Humboldt Strategic Plan Key Findings**

**RePower Humboldt Key Findings**

- A renewable energy future is feasible.
- It will have beneficial economic, security, and environmental impacts.
- Energy efficiency is our cheapest option and should be maximized.
- Biomass, wind and small hydro can play a significant supply side role.
- Fuel switching, like electric vehicles, can play a key role.
- Distributed generation can play an important role, but utility-scale generation is also necessary.
- A mix of power options is needed.
- Multiple power options are available and they offer trade-offs.
- All power supply options have impacts, including the “do nothing” option.
- The PG&E Humboldt Bay Generating Station provides important energy services and is well suited to support local renewable energy development.
- Significant transmission and distribution system upgrades will be necessary to accommodate large-scale renewable energy development.

Source: Schatz Energy Research Center.

### 3.6.1 Long-term Strategies and Near-term Implementation Measures

The long-term strategies presented in the RePower Humboldt Strategic Plan are listed below, followed by the summary table of near-term implementation measures (Figure 3.17).

#### **RePower Humboldt Long-term Strategies**

- Engage the community in the adoption and implementation of the RePower Humboldt vision and plan.
- Aggressively pursue cost-effective energy efficiency opportunities.
- Develop local renewable energy resources.
- Adopt plug-in electric vehicles.
- Adopt heat pumps for water and space heating.
- Develop distributed generation projects.
- Pursue cost-effective and sustainable means to access forest management residues for biomass energy applications.
- Work to develop Humboldt County as a center for wave energy and offshore wind energy research and demonstration.
- Work with PG&E to plan for long-term electric grid infrastructure upgrades.
- Work with regulatory agencies to assess and reduce permitting barriers to renewable energy project development.
- Create options for local development and ownership of renewable energy projects.
- Develop options for local consumers to purchase local renewable energy.
- Develop options to finance local renewable energy projects.
- Evaluate and adapt the RePower Humboldt Strategic Plan.

**Figure 3.17: RePower Humboldt Strategic Plan Summary Table of Near-Term Implementation Measures**

Measure #	Associated Long-Term Strategy	Implementation Measure	Responsible Parties & Partners	Key Milestones / Time frame	Potential Funding Resources	Related Resources
IM1	LTS1	Secure endorsement of RePower Humboldt Strategic Plan from key constituencies, form leadership group	Municipalities, RCEA, SERC	Complete in 2013		
IM2	LTS1	Coordinate with local Tribes	Tribal Governments, municipalities, RCEA	Ongoing		
IM3	LTS1	Work to integrate RePower Humboldt activities into local climate action plans	Municipalities, RCEA	2013 program initiation		Existing climate action plans
IM4	LTS1	Implement a RePower Humboldt education and outreach program	RCEA, SERC, HSU, PG&E, municipalities, Tribes	2013-2014		RePower Humboldt Education & Outreach Plan
IM5	LTS2	Expand RCEA's energy efficiency efforts	RCEA, PG&E, municipalities	2012 program initiation, ongoing	Utility & state funding, cap & trade revenues	
IM6	LTS2	Implement existing Title 24 code & consider adopting stricter energy efficiency standards for new construction	RCEA, municipalities	Initiate in 2015	Utility & state funding	
IM7	LTS3	Promote development of run-of-river hydroelectric power	Municipalities, RCEA, SERC, PG&E, economic development, Tribes	Initiate in 2013	State & federal funding	1982 Oscar Larson report, FERC
IM8	LTS3	Support responsible wind energy development	RCEA, municipalities, SERC, PG&E, economic development, land owners	Ongoing		
IM9	LTS3	Designate "Renewable Energy Parks"	RCEA, SERC, PG&E, municipalities, economic development, Harbor District	Initiate in 2013	State & federal funding	RePower Humboldt Regulatory & Policy Guide
IM10	LTS4	Develop Plug-in Electric Vehicle (PEV) Readiness Plan	RCEA, SERC, PG&E, municipalities, GHD, Tribes	Underway, study complete in 2014	Already funded by CEC	
IM11	LTS4	Promote PEV adoption	RCEA, SERC, PG&E, municipalities, GHD, Tribes	2013 program initiation, ongoing	Local, state, federal, private grants.	PEV Readiness Plan (IM10)

Source: Schatz Energy Research Center.

**Figure 3.17: RePower Humboldt Strategic Plan Summary Table of Near-Term Implementation Measures (cont.)**

Measure #	Associated Long-Term Strategy	Implementation Measure	Responsible Parties & Partners	Key Milestones / Time Frame	Potential Funding Resources	Related Resources
IM12	LTS4	Streamline permitting for PEV charging infrastructure	RCEA, municipalities, GHD	2013-2015		PEV Readiness Plan (IM10)
IM13	LTS4	Install PEV charging infrastructure	Municipalities, HSU, businesses, Tribes	Ongoing	Local, state, federal grants. Private investment.	PEV Readiness Plan (IM10)
IM14	LTS5	Conduct a heat pump pilot study to demonstrate heat pumps and assess heat pump impacts	RCEA, SERC, PG&E, businesses	Initiate study in 2013	State & federal grants	
IM15	LTS5	Develop a heat pump promotion program	RCEA, municipalities, SERC, PG&E, businesses	2015 program initiation, ongoing	Local, state, federal and private grants.	
IM16	LTS6	Promote distributed generation projects	HWMA, municipalities, RCEA, SERC, HSU, Tribes	Ongoing	State & federal grants	
IM17	LTS7	Conduct research on woody biomass to energy in Humboldt County	RCEA, SERC, local forest products industry, forest restoration community, HSU Forestry department	Initiate study in 2013	Local, state, federal grants. Private grants from industry.	
IM18	LTS3, LTS7	Form a biomass energy working group	RCEA, SERC, forest products industry, Forest Service, sustainable forestry/environmental groups, Tribes	Initiate in 2013		CA Biomass Collaborative, UC Berkeley Woody Biomass Utilization Group
IM19	LTS8	Attract wave energy research, development, and demonstration projects	SERC, HSU, RCEA, economic development, Harbor District	Initiate in 2013, ongoing	State & federal grants	Oregon State Univ.
IM20	LTS8	Pursue opportunities for off-shore wind energy research, development and demonstration	SERC, HSU, RCEA, economic development, Harbor District	Initiated in 2012, ongoing	USDOE, state & federal grants	

Source: Schatz Energy Research Center.

**Figure 3.17: RePower Humboldt Strategic Plan Summary Table of Near-Term Implementation Measures (cont.)**

Measure #	Associated Long-Term Strategy	Implementation Measure	Responsible Parties & Partners	Key Milestones / Time Frame	Potential Funding Resources	Related Resources
IM21	LTS8	Pursue opportunities for osmotic power research and other energy research at National Marine Research & Innovation Park	SERC, HSU, RCEA, economic development, Harbor District, HBWMD	Initiated in 2013, ongoing	USDOE, state & federal grants	
IM22	LTS9	Assess needs and opportunities for transmission and distribution system upgrades	SERC, RCEA, PG&E, municipalities, CAISO	Initiate in 2014	State & federal grants, utility funds	
IM23	LTS10	Form a renewable energy permitting working group	Municipalities, RCEA, SERC, PG&E, regulatory agencies & consultants	2013 program initiation, ongoing		RePower Humboldt Regulatory & Policy Guide, CEC Local Government Planning Resources
IM24	LTS11	Develop a turn-key purchase program	RCEA, installers, distributors	2013 program initiation		Existing RCEA Energy Watch Program
IM25	LTS11, LTS12	Form a working group for the local development and ownership of renewable energy projects and consumer access to resulting energy	Municipalities, RCEA, SERC	2013 program initiation		RePower Humboldt Regulatory & Policy Guide, other regional jurisdictions like Marin & Sonoma
IM26	LTS12	Purchase local renewable energy via Direct Access agreement	HSU, businesses		Humboldt Energy Independence Fund	
IM27	LTS13	Form a working group to create financing options for renewable energy project development	Municipalities, RCEA, banks, Headwaters Fund, Humboldt Area Foundation	2013 program initiation	Cap & trade auction revenues, local capital	RePower Humboldt Regulatory & Policy Guide, Sonoma County financing program
IM28	LTS14	Develop and implement an evaluation plan	RCEA, RePower Humboldt leadership group	2013-2014 initiation		Draft Evaluation Metrics (Ch. 11)

Source: Schatz Energy Research Center.

## 3.7 Community Outreach

RePower Humboldt community outreach efforts have included preparation of outreach materials, engagement in outreach activities, and development of an community outreach plan to move the RePower Humboldt vision forward. A brief listing of outreach activities is provided in this section.

### 3.7.1 Outreach Activities

The project team performed a large number of outreach activities as part of the RePower Humboldt project, including public presentations, television appearances, radio talk show appearances, and articles and editorials for local news publications. Table 3.3 provides a list of outreach activities conducted during the project period. In addition, the team created an electronic mailing list that serves to inform 80 community members about RePower Humboldt activities.

### 3.7.2 Outreach Materials

Outreach materials developed for the RePower Humboldt project are listed below.

- **PowerPoint presentations.** The project team gave many RePower Humboldt presentations throughout the three-year project period. The team prepared a PowerPoint presentation for each event and used these presentations to communicate the RePower Humboldt vision and to describe the activities and findings of the RePower Humboldt study.
- **RePower Humboldt Strategic Plan – full document and executive summary.** The RePower Humboldt Strategic Plan is the culminating document for the project. It summarizes the results of the project, articulates the RePower Humboldt vision, and lays out an action plan for moving forward. The team desktop published the strategic plan and associated executive summary document in a user-friendly format full of graphics and pictures that make them easily accessible to the general public.
- **RePower Humboldt web page.** The RePower Humboldt web page is one of the key pages on the Redwood Coast Energy Authority’s main website. It provides a way to keep the community up-to-date on project activities and efforts to move the plan forward. The web page includes a brief description of the project and provides access to the RePower Humboldt Strategic Plan and an associated PowerPoint presentation that the team delivered at the RePower Humboldt town hall meeting on September 26, 2012. In addition, all published documents associated with the RePower Humboldt project are available for download on the web page. RCEA’s main website also has links to many programs and services that relate to the RePower Humboldt vision. These include: Redwood Coast Energy Watch partnership, climate action planning, Redwood Neighborhood Energy Challenge, North Coast Plug-in Electric Vehicle Project, Energy Upgrade California, and Humboldt County’s General Plan Update, including the Energy Element and Comprehensive Action Plan for Energy.

- **Additional web pages.** The Schatz Energy Research Center has also maintained a Repower Humboldt web page. This page has been used to provide basic information on the project and to make available key project documents and presentations. In addition, SERC has maintained a web page regarding wind power in Humboldt County, with a particular focus on the proposed Shell WindEnergy project on Bear River Ridge. This page includes basic project information, a list of frequently asked questions, a Google Earth virtual tour of the proposed project, links to SERC documents and interviews concerning the proposed project, and links to other resources.

**Table 3.3: RePower Humboldt Outreach Activities**

<b>Date</b>	<b>Event</b>
April 3, 2010	Plan It Green Conference, RESCO presentation
April 13, 2010	RESCO Symposium at UC Davis
July 1, 2010	RESCO Meeting with Jim Patterson, San Luis Obispo County Supervisor
November 18, 2010	RESCO Stakeholder Meeting
December 1, 2010	KEET-TV (PBS-Ch13) Energy Round Table
December 2, 2010	HSU Sustainable Futures Speaker Series, RESCO resource and technology assessment
December 10, 2010	KHSU radio interview
January 26, 2011	KHUM radio interview
February 5, 2011	College of the Redwoods Green Jobs Career Fair, RESCO presentation
February 22, 2011	RESCO Symposium at UC Davis
February 24, 2011	Humboldt State University Sustainable Futures Speaker Series, RESCO economic impact
April 1, 2011	Plan It Green Conference, RESCO Youth Stakeholder Meeting
April 2, 2011	Plan It Green Conference, RESCO presentation
April 13, 2011	RESCO Stakeholder Meeting
April 21, 2011	KMUD radio interview
April 26, 2011	CA Air Pollution Control Officer's Association Meeting, RESCO presentation
May 12, 2011	KHUM radio interview
May 12, 2011	KMUD radio interview
July 6, 2011	Outreach meeting with Humboldt State University Sustainability Staff
September 20, 2011	RESCO presentation to HSU Graduate Seminar Class
September 22, 2011	Wind power interview on KHSU radio
October 10, 2011	Meeting with Sonoma RESCO
October 13, 2011	RCEA Special Insert to the North Coast Journal w/ page about the Humboldt RESCO Project
November 17, 2011	UC Davis Net Zero Symposium, RESCO presentation
December 24, 2011	Editorial in Eureka Times-Standard "Wind power makes sense for Humboldt County"
January 5, 2012	Wind power presentation at the Ferndale City Council Meeting
February 8, 2012	Local government low-carbon future panel discussion at HSU
March 1, 2012	Wind power interview on KSLG radio
March 24, 2012	KMUD radio interview (Bear River Ridge wind power project)
May 22, 2012	KHSU radio interview
June 26, 2012	KHSU radio interview (part 2)
July 18, 2012	Editorial in Eureka Times-Standard "Shell WindEnergy is gone; now what?"
July 20, 2012	Plan It Green Conference, RESCO presentation
Aug/Sept 2012	Humboldt RESCO article for the Econews (Northcoast Environmental Center newsletter)
September 18, 2012	Press release, public release of RePower Humboldt Strategic Plan
September 18, 2012	Press conference in Eureka, release of RePower Humboldt Strategic Plan
September 20, 2012	HSU Sustainable Futures Speaker Series, RePower Humboldt Strategic Plan presentation
September 25, 2012	RESCO presentations to HSU Engineering and Graduate classes
September 25, 2012	KHUM radio interview
September 25, 2012	KMUD radio interview
September 26, 2012	RESCO Town Hall Meeting, Wharfinger Building, Eureka
October 9, 2012	RESCO presentation to HSU Emeritus Faculty
October 11, 2012	RePower Humboldt "My Word" Editorial in Eureka Times-Standard
October 15, 2012	RESCO presentation to RCEA Board
October 15, 2012	RESCO presentation to City of Arcata Energy Committee
October 23, 2012	RESCO presentation to Garberville Rotary
November 2, 2012	RESCO presentation to Southwest Eureka Rotary

Source: Schatz Energy Research Center.

### 3.7.3 Outreach Plan

The RePower Humboldt outreach plan is meant to serve as a guide for community outreach and education that will further engage the community and secure ongoing support for development of Humboldt County as a renewable energy secure community. Broad public support, participation, and commitment are essential to successful implementation of the Strategic Plan and were identified as a key part of the long-term strategy for achieving the RePower Humboldt vision. The outreach plan outlines two main strategies that will engage key stakeholders in the community and engage the broader public.

- **Secure the support of local municipalities, agencies and community organizations.**  
The RePower Humboldt project team will present the RePower Humboldt vision and Strategic Plan to local municipalities, agencies, and community organizations and will work to secure their endorsements or other expressions of support. In addition, the project team will identify specific actions these groups can take to support the Strategic Plan objectives. Groups to be engaged include, but are not limited to the following.
  - City and county governments
  - Local Native American Tribes
  - Humboldt Bay Municipal Water District
  - Humboldt Bay Harbor, Recreation and Conservation District
  - North Coast Unified Air Quality Management District
  - Redwood Region Economic Development Commission
  - Humboldt County Farm Bureau
  - Humboldt Waste Management Authority
  - Northcoast Environmental Center
- **On-going education and outreach efforts. The team identified** implementation of a RePower Humboldt education and outreach program as a near-term action item to pursue once endorsements from key constituencies have been secured. The program will include a coordinated education and outreach campaign that communicates the findings and recommendations of the RePower Humboldt Strategic Plan, solicits public input, works to build consensus for the plan, and mobilizes public action on the implementation strategies. Key aspects of the education and outreach program will include:
  - Develop an increased online presence through the Redwood Coast Energy Authority web page. Add a media section, a community bulletin board, a consumer action guide, frequently asked questions, case study highlights, and other information resources.
  - Research and document case studies that showcase local commercial and residential renewable energy and energy efficiency projects.
  - Form working groups and/or a volunteer task force that can extend the reach of the RePower Humboldt project team.

- Host quarterly workshops to highlight key informational topics. A sample timeline and list of topics is given below.
  - Spring 2013: Transportation and Fuel Switching
  - Summer 2013: Biomass
  - Fall 2013: Solar
  - Winter 2013: Wind
  - Spring 2014: Wave
  - Summer 2014: Small Hydro
  - Fall 2014: Ownership, Purchasing and Financing Options
  - Winter 2014: Transmission and Distribution Upgrades

### **3.8 RESCO Planning Workbook**

The purpose of the Humboldt RESCO Planning Workbook is to outline Humboldt County’s strategic planning process so that other communities can learn from the experience and can employ similar strategic planning methods in their quest for renewable energy security. The planning workbook provides an overview of the planning process and discusses each of the key project tasks. For each task, the workbook provides information about the goals and objectives, actions taken, data or information resources used, deliverables, and lessons learned. The project team also shares insights about some of the energy planning and analysis decisions that were made, especially regarding the use of energy planning and economic impact assessment modeling tools. Project results are not presented or discussed. The reader is referred to other project documentation for further information.

A few key lessons cited in the workbook include:

- Sustainable energy planning at the local government level, especially in California’s rural counties, is a rather new phenomenon. A sufficient amount of capacity building needs to take place because many local governments need support in this new arena.
- A comprehensive state guide on sustainable energy planning for local governments is needed. This effort could build on key planning guides already produced by the Energy Commission, including the *Energy Aware Planning Guide* (California Energy Commission, 2011b) and the *Energy Aware Facility Siting and Permitting Guide* (Phinney et al., 2011). These are tremendously useful resources. However, there are additional informational needs to be filled. To establish a meaningful context, a guide should provide substantial background information regarding the structure and operation of the energy industry (especially electricity, but also natural gas and transportation fuels). This could include information regarding key players, regulatory structure, and options for buying and selling energy. A guide should also discuss state energy policy initiatives and relate them to local government. In addition, key energy terminology

and topics should be defined and discussed, including terms like net metering, distributed generation, renewable energy credits, feed-in tariffs, Community Choice Aggregation, and others. An understanding of this basic background information is necessary for local leaders to be effective in the areas of energy policy and planning. State sponsored workshops and/or trainings could be used to educate local leaders about the energy industry and sustainable energy planning, and to provide them with tools they can use to increase the energy sustainability of their communities.

- Local governments are challenged because they have limited staffing and budget resources, and taking on work in a new area such as local energy planning competes with other program areas for already strained resources.

# CHAPTER 4: Conclusions and Recommendations

## 4.1 Conclusions

The project team met key project goals and objectives. The team produced a strategic action plan for Humboldt County that can lead to development of local renewable energy resources, which in turn can meet the majority of local electricity demand, as well as a significant fraction of heating and transportation energy needs. The plan was well received by the local community, and the community is now engaged in an important dialog regarding the path forward. Humboldt County has a great opportunity to become a renewable energy secure community. The energy resources and necessary technologies exist. The county is now equipped with a well-conceived plan, and community and project team members have begun to develop significant expertise and knowhow to ensure the plan moves forward.

## 4.2 Lessons Learned

- Humboldt County can meet 75 percent or more of its electricity needs and a large fraction of its heating and transportation energy demand using local renewable energy resources. This can result in a substantial reduction in GHG emissions (35 percent to 45 percent below business-as-usual) and can be achieved at a modest cost increase (5 percent to 15 percent above business-as-usual). The key issues facing Humboldt County are not related to the adequacy of local resources, but instead to the ability to develop these resources and the associated energy infrastructure needed to serve local demand with local renewable energy sources.
- There are many possible resource and technology options to choose from, and a mixed portfolio of options is likely more advantageous than any technology in isolation. Aggressive implementation of cost-effective energy efficiency opportunities should be a near-term pursuit. Biomass, wind, and small run-of-the-river hydroelectric energy sources should play a key supply-side role.
- The RESCO goal of meeting 75 percent or more of electric demand with local renewable resources may not be the best metric for measuring success. Instead, the project team recommends the focus be on cost-effective options to decrease *overall* GHG emissions across the whole energy sector.
- Fuel switching to plug-in hybrid and battery-only electric vehicles in the transportation sector and to electric heat pumps in the heating sector has the potential to play a major role in helping Humboldt County to realize its RESCO vision. Fuel switching opportunities are critical to cost-effectively achieving large reductions in energy related GHG emissions. Without fuel switching, deep reductions in GHG emissions are infeasible.

- In addition to energy security and climate change mitigation benefits, the RESCO vision offers Humboldt County significant economic development benefits. The study estimates that 100 to 300 permanent additional full-time jobs could be created through implementation of the RESCO vision.
- An interconnection feasibility study conducted by PG&E indicates that substantial upgrades to the local transmission and distribution system will be required to accommodate large-scale development of local renewable energy sources. The most cost-effective plan for these upgrades would likely involve an area-wide planning approach that simultaneously considers multiple projects. If instead a project-by-project approach is taken, a less optimal piecemeal solution is likely to result. It is also important to note that non-standard approaches to maintaining grid stability, such as curtailing generation, should be considered in the analysis. Finally, transmission planning should also consider the possibility of creating a community-scale microgrid in Humboldt that can operate independently of the statewide grid if necessary, thereby providing added energy security to the Humboldt area.
- Energy storage is not expected to play a significant role in the near or even intermediate term. This is due to the tremendous load following capabilities of the PG&E HBGS and the 70 MW of available transmission capacity connecting the county to the statewide electric grid.
- If there is no further development of clean energy alternatives in Humboldt County, it is expected that the electric supply will be dominated by power from the natural gas-fired PG&E HBGS and existing biomass power plants. The heating and transportation sectors will continue to be dominated by fossil fuels in the form of natural gas for heating and gasoline for transport. Transportation fuels will continue to dominate annual energy costs, and transportation fuels and natural gas usage will drive GHG emissions to 25 percent greater than 1990 levels. Clearly the business-as-usual scenario will not improve local energy sustainability, but instead will exacerbate the environmental problems associated with the current energy system while maintaining Humboldt County's exposure to geographic isolation, fuel scarcity, and price volatility problems.
- On-shore wind power is likely to face siting challenges and could benefit from proactive planning, permitting and outreach efforts.
- Biomass energy faces uncertainties and potential barriers, including fuel costs, sustainability, and public perception and climate neutrality issues.
- Small, run-of-the-river hydroelectric development faces significant regulatory, permitting, and transmission access issues.
- Low natural gas prices and Renewable Portfolio Standard quotas being reached have depressed prices for renewable electricity. While these may be short-lived transient conditions, they currently pose challenges to project developers and owners/operators of both existing and new renewable energy projects.
- A distrust of large corporations can make securing outside capital more challenging and creates a preference for locally owned, community-based projects.

- There is a lack of consumer choice allowing for purchase of renewable energy, especially from local projects.
- There is a strong preference for local participation and control in energy planning and development.
- People want to see real, tangible benefits for their communities associated with proposed projects, especially if they perceive they are giving something up in the process.
- The community can benefit from an education and outreach campaign that provides information about how much energy is consumed, where it comes from, what the alternatives are, and what the associated impacts are.
- Because of community concerns regarding local impacts of renewable energy projects, there is a need for transparent processes that involve the community in planning and project development activities in a meaningful way.
- Planning, permitting, and regulatory hurdles for renewable energy projects point to a need for proactive efforts that can help streamline the project development process, identify preferred sites, develop programmatic environmental reviews, and develop land use zones that are compatible with renewable energy development.

### **4.3 Recommendations**

Key next steps include:

- Implement the education and outreach plan and secure endorsements from key constituencies; form working groups to move the plan forward.
- Work to expand the Redwood Coast Energy Authority’s local energy efficiency efforts.
- Conduct proactive planning and regulatory efforts that can streamline the development process, identify preferred sites, develop programmatic environmental review, and establish renewable energy zones.
- Promote plug-in electric vehicle adoption and deploy charging infrastructure.
- Promote and develop distributed generation projects.
- Develop an “all-in-one” program that offers a full array of energy services in the areas of energy efficiency and distributed generation to both commercial and residential customers. The program should support participants from start to finish in their sustainable energy projects. Services could include: project evaluation; financing; project management; interconnection, permitting, and incentive paperwork; bulk purchasing; standardized pricing; and pre-approved contractors).

### **4.4 Suggestions for Further Research**

- Conduct research, development, and demonstration of biomass energy conversion technologies that can decrease transportation costs, increase system efficiencies, and

provide added value (for example, biomass gasification to fuel cell generator and torrefaction technologies).

- Conduct a biomass energy assessment study to determine the available biomass supply and associated fuel cost for local biomass resources. Assess GHG and forest management implications of local biomass use; work to build a consensus on acceptable biomass energy policy in the county.
- Conduct a heat pump pilot study to assess the performance and cost-effectiveness of air-source heat pumps in the North Coast region. Examine opportunities to streamline permitting and overcome market barriers.
- Pursue opportunities to attract wave energy, offshore wind energy, and osmotic power research, development, and demonstration projects to Humboldt County. Pursue development of a research, development, demonstration, and deployment facility at the former Samoa Pulp Mill site.

#### **4.5 Benefits to California**

- The Humboldt County RESCO Strategic Plan will support Humboldt County and other communities throughout the state to develop local renewable energy resources and implement sustainable energy policies. These efforts will help the State of California meet many of its energy and climate protection goals, including: Renewable Portfolio Standard, Alternative Fuels Plan, Zero Emission Vehicle Action Plan, Bioenergy Action Plan, Clean Energy Jobs Plan, Distributed Generation and Cogeneration Policy, and AB 32 Global Warming Solutions Act of 2006.
- Local community energy planning is a new policy and planning area. The policy and planning tools developed through the Humboldt County RESCO project will provide significant value to many other California communities. The strategic planning process has been documented in the RESCO Planning Workbook to make this information easily accessible to other communities and to facilitate replication.
- Many lessons (for example, the importance of electric vehicles) have been learned through the energy planning and analysis work, assessment of regulatory and political issues, and stakeholder analysis process. Many if not all of these lessons are transferrable to other communities. These lessons learned have been made easily accessible to other communities via the RESCO Planning Workbook.
- The RESCO Strategic Plan identifies cost-effective approaches to improving energy sustainability and mitigating climate change and demonstrates that there are energy, environment and economic benefits to be gained. These positive impacts can benefit ratepayers throughout the state.

## CHAPTER 5: References

- American Council for an Energy Efficient Economy (ACEEE). 2009. *Saving Energy Cost Effectively: A National Review of the Cost of Energy Saved Through Utility-Sector Energy Efficiency Programs*. <http://www.aceee.org/research-report/u092>. [Accessed November 6, 2010].
- Black and Veatch. 2010. *Renewable Energy Transmission Initiative (RETI) Phase 2B Final Report*. <http://www.energy.ca.gov/reti/documents/index.html>. [Retrieved June 14, 2010].
- Burgess, R. 2010. Owner of Three Forks Water Power Project. Personal communication.
- California Department of Conservation. 2013. Online Production and Injection Query for State of California, Department of Conservation, Division of Oil, Gas, and Geothermal Resources. <http://opi.consrv.ca.gov/opi/opi.dll>. [Retrieved February 14, 2013].
- California Department of Transportation. 2009. "2008 California Motor Vehicle Stock, Travel and Fuel Forecast." Prepared by Division of Transportation System Information. June 2009. <http://www.dot.ca.gov/hq/tsip/otfa/tab/mvstaff.html>.
- California Department of Water Resources. 1985. *California Wind Atlas*. Prepared for the California Energy Commission. Contract Number P-500-82-044.
- California Energy Commission. 2013. California Energy Consumption Data Management System. <http://www.ecdms.energy.ca.gov/elecbycounty.aspx>. [Retrieved February 14, 2013].
- California Energy Commission. 2011a. Energy Almanac, Retail Fuel Outlet Survey. [http://energyalmanac.ca.gov/gasoline/piira\\_retail\\_survey.html](http://energyalmanac.ca.gov/gasoline/piira_retail_survey.html). [Retrieved February 14, 2013].
- California Energy Commission. 2011b. *Energy Aware Planning Guide*. Commission Report. CEC-600-2009-013. February 2011.
- California Energy Commission. 2010a. California Solar Photovoltaic Statistics and Data. <http://www.energyalmanac.ca.gov/renewables/solar/index.html>. [Accessed June 6, 2010].
- California Energy Commission. 2010b. Electricity and natural gas consumption data for Humboldt County from the California Energy Consumption Database. Provided by Steven Mac of the California Energy Commission, 2010.
- California Energy Commission. 2007. *Distributed Generation and Cogeneration Policy Roadmap for California*. Staff Report. March 2007.
- California Energy Commission. 2003. "California Ocean Wave Energy Assessment, Volume 1, Draft." August 2003.

- California State Board of Equalization. 2010. California Timber Harvest by County. Year 2010. Report YT-36. <http://www.boe.ca.gov/proptaxes/pdf/yr3694to10.pdf>. [Retrieved February 14, 2013].
- Electric Power Research Institute (EPRI). 2009. *Offshore Ocean Wave Energy: A Summer 2009 Technology and Market Assessment Update*. EPRI-WP-013-OR. <http://www.oregonwave.org/wp-content/uploads/Task-2.1.1ePRI-Waveenergy-Tech-Assessment-2009.pdf>. [Retrieved June 18, 2010].
- Electric Power Research Institute (EPRI), Natural Resource Defense Council (NRDC). 2007. *Environmental Assessment of Plug-In Hybrid Electric Vehicles*, Volume 1: Nationwide Greenhouse Gas Emissions. <http://mydocs.epri.com/docs/CorporateDocuments/SectorPages/Portfolio/PDM/PHEV-ExecSum-vol1.pdf>. [Accessed December 7, 2010].
- Electric Transportation Engineering Corporation (ETEC). 2010. *Long-Range EV Charging Infrastructure Plan For Western Oregon* (Draft, Version 1.3).
- Energy and Environmental Economics, Inc. (E3). 2008. New Generation Cost Summary. <http://www.ethree.com/GHG/30%20Generation%20Cost%20Summary%20v3.doc>. [Retrieved May 10, 2010].
- Energy and Environmental Economics, Inc. (E3) and Rocky Mountain Institute (RMI). 2004. *A Forecast of of Cost Effectiveness Avoided Costs and Externality Adders*. Prepared for CPUC.
- Energy Efficiency and Renewable Energy (EERE), US Department of Energy. 2009. *2008 Renewable Energy Data Book*. [http://www1.eere.energy.gov/maps\\_data/pdfs/eere\\_databook\\_091208.pdf](http://www1.eere.energy.gov/maps_data/pdfs/eere_databook_091208.pdf). [Retrieved May 10, 2010].
- Energy Information Administration (EIA), US Department of Energy. 2009. *Assumptions to the Annual Energy Outlook 2009*. DOE/EIA-0554-2009. [http://www.eia.doe.gov/oiaf/aeo/assumption/pdf/0554\(2009\).pdf](http://www.eia.doe.gov/oiaf/aeo/assumption/pdf/0554(2009).pdf). [Retrieved May 15, 2010].
- Hackett, S., L. Scheidler, and R. Garcia Jr. (Schatz Energy Research Center). 2012. *Humboldt County as a Renewable Energy Secure Community: Economic Analysis Report*. California Energy Commission.
- Humboldt Bay Municipal Water District (HBMWD). 2010. Production data for hydropower plant at Matthew's Dam, Ruth Lake.
- Humboldt County, California. 2005. *Humboldt 21st Century Natural Resources and Hazards Report*, [http://www.planupdate.org/meetings/natl\\_res/nr\\_report.asp](http://www.planupdate.org/meetings/natl_res/nr_report.asp). [Retrieved March, 2005].
- Humboldt Waste Management Authority. 2010. Humboldt Food Waste Digester Project Summary. <http://www.hwma.net/index.php?a=foodwaste>. [Retrieved June, 2010].
- Itron. 2008. *California Energy Efficiency Potential Study*. CALMAC Study ID: PGE0264.01.

- Kammen, D., K. Kapadia, and M. Fripp. 2006. *Putting Renewables to Work: How Many Jobs Can the Clean Energy Industry Generate?* RAEI Report, University of California, Berkeley.  
<http://rael.berkeley.edu/old-site/renewables.jobs.2006.pdf>
- KEMA, Inc. 2009. *Renewable Energy Cost of Generation Update*. CEC 500-2009-084. Sacramento, CA: California Energy Commission.
- Klein, J. 2010. *Comparative Costs of California Central Station Electricity Generation Technologies*. California Energy Commission. CEC-200-2009-07SF.
- Klein, J., and A. Rednam. 2007. *Comparative Costs of California Central Station Electricity Generation Technologies*. California Energy Commission, Electricity Supply Analysis Division. CEC-200-2007-011.
- Lazard Ltd. 2008. *Levelized Cost of Energy Analysis - Version 2.0*. Presentation to the National Association of Regulatory Utility Commissioners.  
<http://www.narucmeetings.org/Presentations/>. [Retrieved May 5, 2010].
- Marino, B. 2010. Power plant production for DG Fairhaven Power LLC. Furnished personally by Bob Marino, General Manager.
- McKinsey & Company. 2007. *Reducing U.S. Greenhouse Gas Emissions: How Much at What Cost? U.S. Greenhouse Gas Abatement Mapping Initiative Report Inputs*.  
<http://www.mckinsey.com/client-service/sustainability/Costcurves.asp>. [Retrieved May 15, 2010].
- National Oceanic and Atmospheric Administration (NOAA). 2010. National Data Buoy Center, Station 46022. [http://www.ndbc.noaa.gov/station\\_page.php?station=46022](http://www.ndbc.noaa.gov/station_page.php?station=46022). [Accessed 2010].
- National Renewable Energy Laboratory (NREL). 2010a. Western Wind Resource Dataset.  
[http://wind.nrel.gov/Web\\_nrel/](http://wind.nrel.gov/Web_nrel/). [Accessed 2010].
- National Renewable Energy Laboratory (NREL). 2010b. National Solar Radiation Database: 1991-2005 Update. Arcata Airport – Site 725945.
- National Renewable Energy Laboratory (NREL). 2009. *The Jobs and Economic Development Impact Model (JEDI): About JEDI and Frequently Asked Questions (FAQ)*.  
[http://www.nrel.gov/analysis/jedi/pdfs/jedi\\_manual\\_0708.pdf](http://www.nrel.gov/analysis/jedi/pdfs/jedi_manual_0708.pdf). [Retrieved August 2, 2009].
- North American Electric Reliability Corporation. 2009. *Accommodating High Levels of Variable Generation to Ensure the Reliability of the Bulk Power System*. Special Report: April 2009.  
<http://www.nerc.com/filez/ivgtf.html> [Accessed August 2011].
- O'Donnell, C., P. Baumstark, V. Nibler, K. Corfee, and K. Sullivan (KEMA). 2009. *Renewable Energy Cost of Generation Update*, PIER Interim Project Report. California Energy Commission. CEC-500-2009-084.

- Oscar Larson & Associates. 1982. *An Analysis of Small Hydroelectric Planning Strategies*. Prepared for: Humboldt County Board of Supervisors. May 1982.
- Pacific Gas and Electric Company. 2012. E-mail correspondence with Ivan Marruffo, Senior Account Representative, March 15, 2012.
- Pacific Gas and Electric Company. 2011a. *Humboldt County RESCO – Interconnection Feasibility Study*. June 10, 2011.
- Pacific Gas and Electric Company. 2011b. *PG&E WaveConnect Program Final Report*. U.S. Department of Energy Report DOE/GO/18170-1. December 2011.
- Pacific Gas and Electric Company. 2010. Humboldt Area electric load 15-minute interval data provided for upon request.
- Phinney, S., E. Capello, and P. Cole (Aspen Environmental Group). 2011. *Energy Aware Facility Siting and Permitting Guide*. California Energy Commission. Publication number: CEC-600-2010-007.
- PIER. 2007. *Summary of PIER Funded Wave Energy Research*, California Energy Commission, PIER Program. CEC-500-2007-083. <http://www.energy.ca.gov/2007publications/CEC-500-2007-083/CEC-500-2007-083.PDF>. [Retrieved June 18, 2010].
- Price, S., and R. Margolis. 2010. *2008 Solar Technologies Market Report, Energy Efficiency & Renewable Energy*, US Department of Energy. <http://www1.eere.energy.gov/solar/pdfs/46025.pdf>. [Accessed February 2011].
- Reis, A. and R. Engel. 2003. *Feasibility Study on Implementing Anaerobic Digestion Technology on Humboldt County Dairy Farms*. Schatz Energy Research Center, Humboldt State University, Arcata, CA, June 1, 2003. Prepared for Humboldt County Economic Development Office.
- Roland-Horst, D. 2008. *Energy Efficiency, Innovation, and Job Creation in California*. Center for Energy, Resources, and Economic Sustainability, University of California, Berkeley.
- Schatz Energy Research Center. 2013a. *Regulatory and Policy Guide on Renewable Energy and Energy Efficiency for Humboldt County Local and Tribal Governments*. Prepared for the Redwood Coast Energy Authority. February 2013.
- Schatz Energy Research Center. 2013b. *RePower Humboldt: A Strategic Plan for Renewable Energy Security and Prosperity*. Prepared for the Redwood Coast Energy Authority. February 2013.
- Schatz Energy Research Center. 2005. *Humboldt County Energy Element Appendices: Technical Report*. Prepared for Redwood Coast Energy Authority. October 2005.
- Shell WindEnergy Inc. 2007. Bear River Wind Power Project, Project Description. Prepared for Humboldt County Community Development Services, Planning Department.

- SWEEP. 2002. *The New Mother Lode: The Potential for More Efficient Electricity Use in the Southwest*. Southwest Energy Efficiency Project. Report for the Hewlett Foundation Energy Series. November 2002.
- U.S. Census. 2000. United States Census 1990 and 2000. Available online at <http://factfinder.census.gov>. [Accessed August 16, 2010].
- U.S. Geological Survey (USGS). 2010. Daily discharge data at USGS Station 11480410. [http://waterdata.usgs.gov/nwis/dv?referred\\_module=sw&site\\_no=11480410](http://waterdata.usgs.gov/nwis/dv?referred_module=sw&site_no=11480410). [Accessed 2010].
- Wei, M., S. Patadia and Kammen, D. 2010. Putting renewables and energy efficiency to work: How many jobs can the clean energy industry generate in the US? *Energy Policy*, 38(2), 919-931.
- Western Regional Climate Center. 2010. Alderpoint precipitation data. <http://www.raws.dri.edu/cgi-bin/rawMAIN.pl?caCAPT>. [Accessed 2010].
- Wheeler, M. 2005. Humboldt County Planning Division, Eureka, CA. Telephone conversation with: Michael Winkler (Schatz Energy Research Center). February 2005.
- Williams, R. 2008. *An Assessment of Biomass Resources in California, 2007*. Department of Biological and Agricultural Engineering, University of California, Davis. March 2008.
- Wiser, R.; G. Barbose, C. Peterman, and N. Darghouth. 2009. *Tracking the Sun II. The Installed Cost of Photovoltaics in the U.S. from 1998–2008*. Berkeley, CA: Lawrence Berkeley National Laboratory. <http://eetd.lbl.gov/ea/EMS/re-pubs.html>. [Accessed February 2011].
- Zoellick, J., C. Sheppard, and P. Alstone. (Schatz Energy Research Center, Humboldt State University). 2012. *Humboldt County as a Renewable Energy Secure Community: Resource and Technology Assessment Report*. California Energy Commission.

## CHAPTER 6: Glossary

AB	Assembly Bill
ACEEE	American Society for an Energy Efficient Economy
BAU	business-as-usual
BEV	battery electric vehicle
CA	California
CAES	compressed air energy storage
CAISO	California Independent System Operator
CCA	Community Choice Aggregation
CG	conventional gasoline
CHP	combined heat and power
CIDIV	compression-ignition direct-injection vehicle
CPUC	California Public Utilities Commission
CV	conventional vehicle
DG	distributed generation
E85	ethanol
EERE	Energy Efficiency and Renewable Energy
EIA	Energy Information Administration
EPRI	Electric Power Research Institute
ETEC	Electric Transportation Engineering Corporation
EV	electric vehicle
EWP	East-West Corporation
FCHV	fuel cell hybrid vehicle
FFV	flex-fuel vehicle
FTD	Fischer-Tropsch diesel
FTE	full-time equivalent
GHG	greenhouse gas
GREET	Greenhouse Gases, Regulated Emissions, and Energy Use in Transportation

GWh	gigawatt-hour
HBGS	Humboldt Bay Generating Station
HBMWD	Humboldt Bay Municipal Water District
IBA	Important Bird Area
IOU	investor-owned utility
IPP	independent power producer
JEDI	Jobs and Economic Development Impact
JPA	Joint Powers Authority
kV	kilovolt
kW	kilowatt
kWh	kilowatt-hour
LCOE	levelized cost of energy
LLC	Limited Liability Corporation
MCF	1,000 cubic feet
MVA	megavolt-amps
MW	megawatt
MWa	megawatt adjusted (adjusted for capacity factor)
MWh	megawatt-hour
NERC	North American Electric reliability Corporation
NOAA	National Oceanic and Atmospheric Administration
NRDC	Natural Resources Defense Council
NREL	National Renewable Energy Laboratory
O&M	operations and maintenance
PAC	Professional Advisory Committee
PACE	Property Assessed Clean Energy
PEV	plug-in electric vehicle
PG&E	Pacific Gas and Electric Company
PHEV	plug-in hybrid electric vehicle
PIER	Public Interest Energy Research
PJ	petajoule
PURPA	Public Utilities Regulatory Policy Act

PV	photovoltaic (solar electric)
RCEA	Redwood Coast Energy Authority
RE	renewable energy
REPOP	Regional Energy Planning Optimization
RESCO	Renewable-based Energy Secure Community
RFG	reformulated gasoline
RMI	Rocky Mountain Institute
SB	Senate Bill
SERC	Schatz Energy Research Center
SI	spark ignition
SWEEP	Southwest Energy Efficiency Project
T&D	transmission and distribution
UC	University of California
URL	uniform resource locator
US	United States
USGS	United States Geological Survey
WTW	well-to-wheels